



# Cisco UCS 5108 Blade Server Chassis

CISCO SYSTEMS  
170 WEST TASMAN DR.  
SAN JOSE, CA, 95134  
[WWW.CISCO.COM](http://WWW.CISCO.COM)

## PUBLICATION HISTORY

REV A.11    DECEMBER 1, 2016

---

# CONTENTS

<b>OVERVIEW</b> . . . . .	<b>3</b>
<b>DETAILED VIEWS</b> . . . . .	<b>5</b>
Chassis Front Views . . . . .	5
Chassis Rear View . . . . .	7
Fabric Extender Modules . . . . .	8
Fabric Interconnect Module . . . . .	9
<b>BASE CHASSIS STANDARD CAPABILITIES and FEATURES</b> . . . . .	<b>10</b>
<b>CONFIGURING the CHASSIS</b> . . . . .	<b>12</b>
STEP 1 VERIFY BASE CHASSIS SKU . . . . .	13
STEP 2 SELECT FABRIC I/O EXTENDERS . . . . .	15
STEP 3 SELECT FABRIC INTERCONNECTS . . . . .	16
STEP 4 CHOOSE ADDITIONAL COMPONENTS (OPTIONAL) . . . . .	17
STEP 5 CHOOSE POWER SUPPLIES . . . . .	21
STEP 6 SELECT AC POWER CORD(s) . . . . .	22
STEP 7 CHOOSE OPERATING SYSTEM (OPTIONAL) . . . . .	23
STEP 8 CHOOSE SERVICE and SUPPORT LEVEL . . . . .	24
<b>SUPPLEMENTAL MATERIAL</b> . . . . .	<b>29</b>
System Overview . . . . .	29
Connectivity Between Blades and Fabric Extenders . . . . .	29
B200 M2/B230 M1/M2Connectivity (Half-Width Blades with One Mezzanine Slot) . . . . .	31
B250 M2/B440 M1/M2 Connectivity (Full-Width Blades with Two Mezzanine Slots) . . . . .	35
B200 M3/M4 Connectivity (Half-Width Blades with Two Mezzanine Slots) . . . . .	39
B420 M3/M4 Connectivity (Full-Width Blade with Three Mezzanine Slots) . . . . .	43
Connectivity Between Fabric Extender and External Fabric Interconnects . . . . .	49
Connectivity Between B200 M3/M4 and Internal 6324 Fabric Interconnects . . . . .	50
SFP+ Transceivers . . . . .	53
Copper SFP+ Twinax Transceivers . . . . .	53
Optical SFP+ Transceivers . . . . .	54
Fabric Extender Bundles . . . . .	55
<b>TECHNICAL SPECIFICATIONS</b> . . . . .	<b>56</b>
Physical Dimensions and Specifications . . . . .	56
Power Specifications . . . . .	58
Environmental Specifications . . . . .	61

## OVERVIEW

The UCS 5108 chassis is a 6RU chassis that can accommodate up to 8 half-width blades or 4 full-width blades, or any combination that will fit in the chassis. The chassis has two I/O bays for Fabric Extenders such as the UCS 2208XP or Fabric Interconnects such as the UCS 6324.

*Figure 1* through *Figure 3 on page 4* show the front and rear views of a 5108 chassis filled with the following blade servers (starting from top):

- Two Cisco UCS B200 M4 half-width blade servers
- One Cisco UCS B250 M2 full-width blade server
- One Cisco UCS B420 M3 full-width blade server
- One Cisco UCS B440 M2 full-width blade server

Figure 1 Cisco UCS 5108 Blade Server Chassis (front view)



Figure 2 Cisco UCS 5108 Blade Server Chassis with Fabric Extenders (rear view)



Figure 3 Cisco UCS 5108 Blade Server Chassis with 6324 Fabric Interconnects (rear view)



# DETAILED VIEWS

## Chassis Front Views

Figure 4 is a detailed front view of the Cisco UCS 5108 Blade Server Chassis with eight half-width blade servers installed.

Figure 4 5108 Chassis Front View With Eight Half-Width Blade Servers Installed

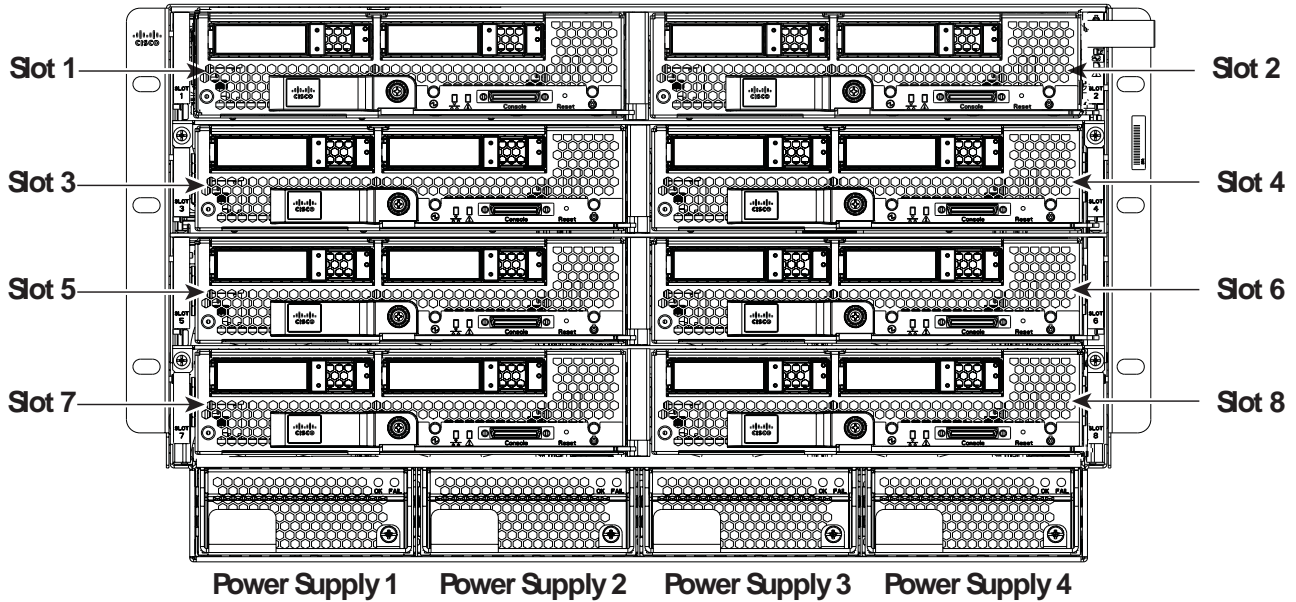

Table 1 Front View Callouts

Callout	Description
Slot 1 - 8	Slot numbering for half-width blade servers
Power Supply 1 - 4	4 x 2500 W power supplies

Figure 5 is a detailed front view of the Cisco UCS 5108 Blade Server Chassis with four full-width blade servers installed.

Figure 5 5108 Chassis Front View With Four Full-Width Blade Servers Installed

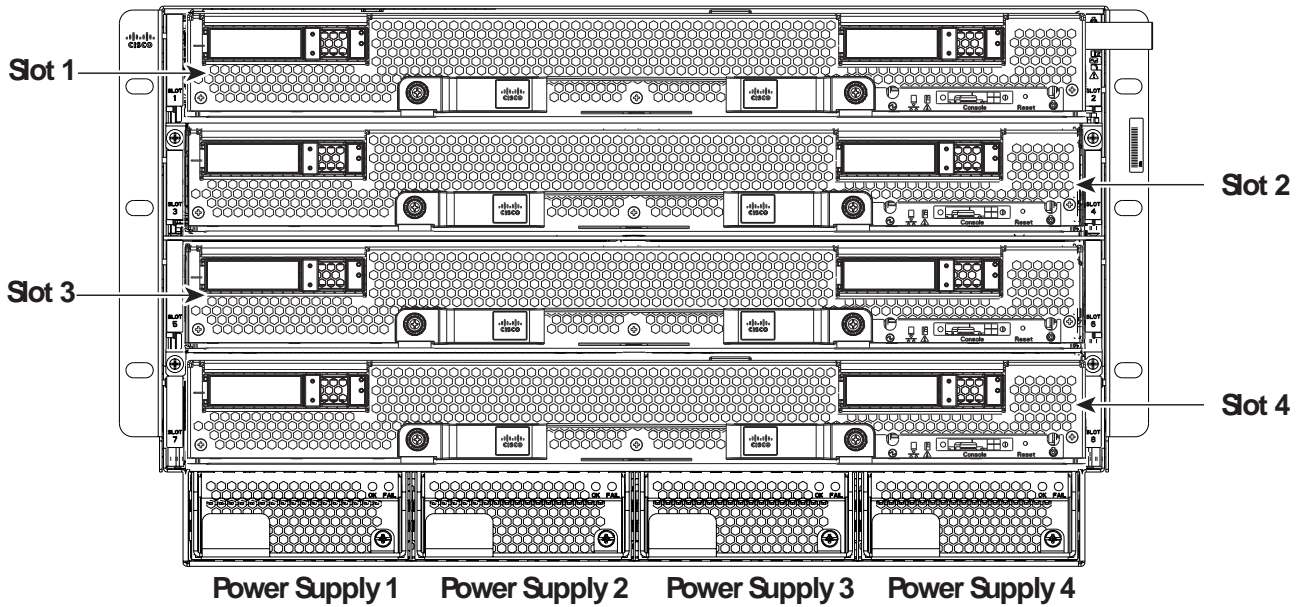

Table 2 Front View Callouts

Callout	Description
Slot 1 - 4	Slot numbering for full-width blade servers
Power Supply 1 - 4	4 x 2500 W power supplies



NOTE: If a B460 M4 full-width blade server is mixed with other full-width or half-width blades in the chassis, the B460 M4 must occupy the bottom two full-width slots in the 5108 chassis.

## Chassis Rear View

Figure 6 shows the rear view of the 5108 chassis (AC power version).

Figure 6 Chassis Rear View (AC power supplies)

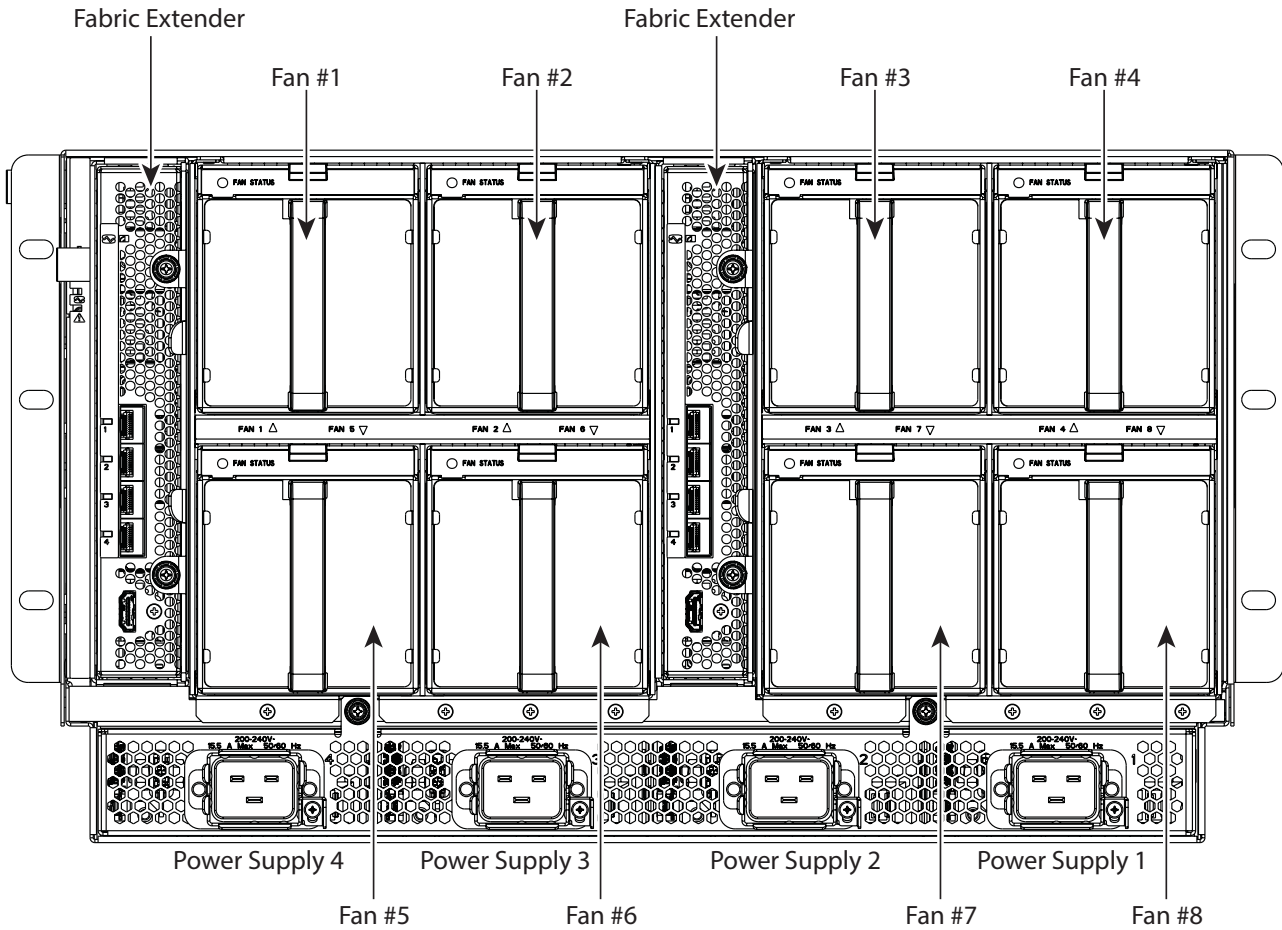

## Fabric Extender Modules

The Fabric Extender modules (up to two) plug into the back of the UCS 5108 series blade server chassis. A midplane connects the blade servers to the Fabric Extenders. The 5108 chassis accommodates the following Fabric Extender modules:

- Cisco UCS 2208XP
- Cisco UCS 2204XP
- Cisco UCS 2104XP

Figure 7 shows the Fabric Extenders.

Figure 7 2208XP, 2204XP, and 2104XP Fabric Extenders

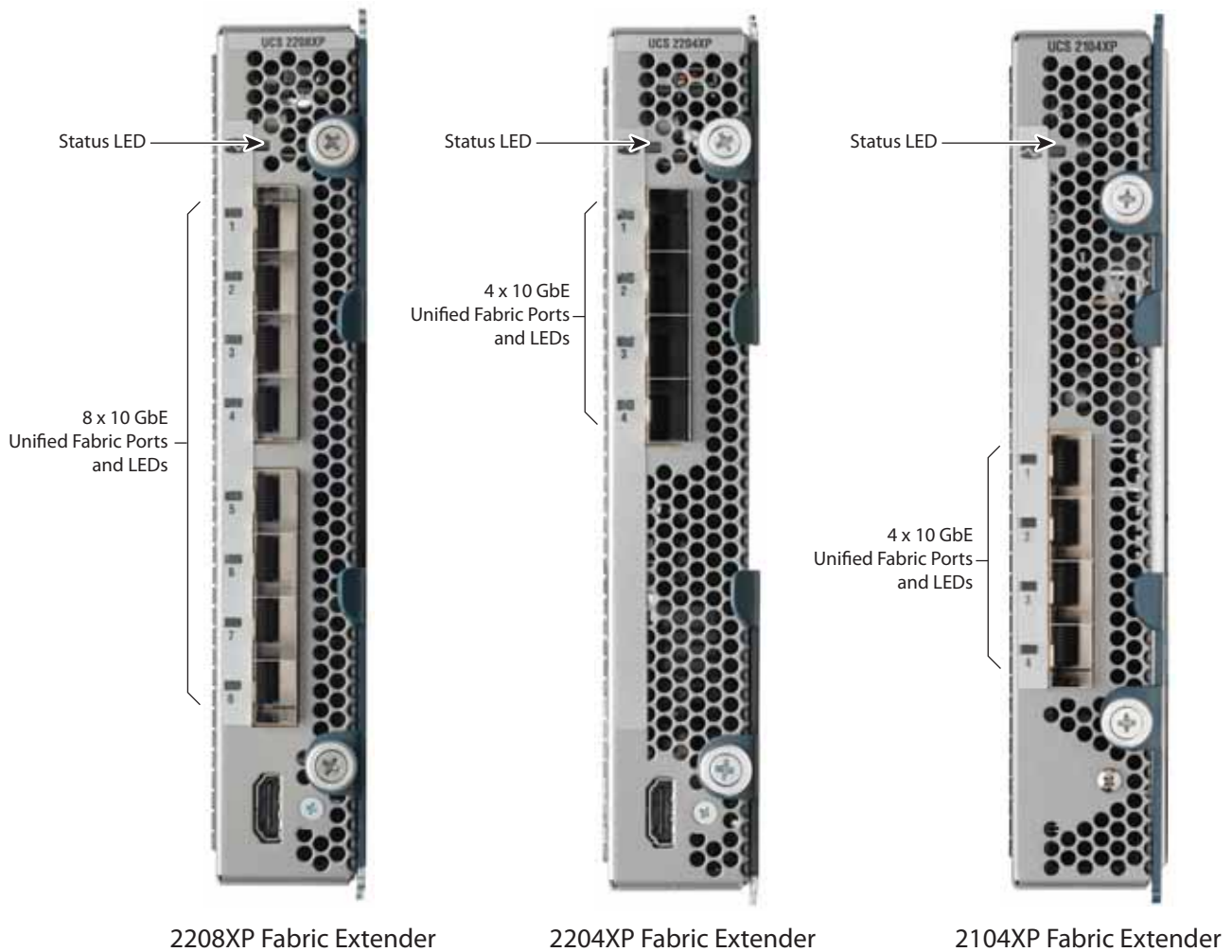



## Fabric Interconnect Module

The Fabric Interconnect modules (up to two) plug into the back of the 5108 series blade server chassis. A midplane connects the blade servers to the Fabric Interconnects. The 5108 chassis accommodates the following Fabric Interconnect module:

- Cisco UCS 6324 Fabric Interconnect



**NOTE:** The Cisco UCS 6324 is supported only in the UCSB-5108-AC2 and UCSB-5108-DC2 chassis. The Cisco UCS 6324 is not currently supported in the UCSB-5108-HVDC chassis.

*Figure 8* shows the Fabric Interconnect.

Figure 8 Cisco UCS 6324 Fabric Interconnect

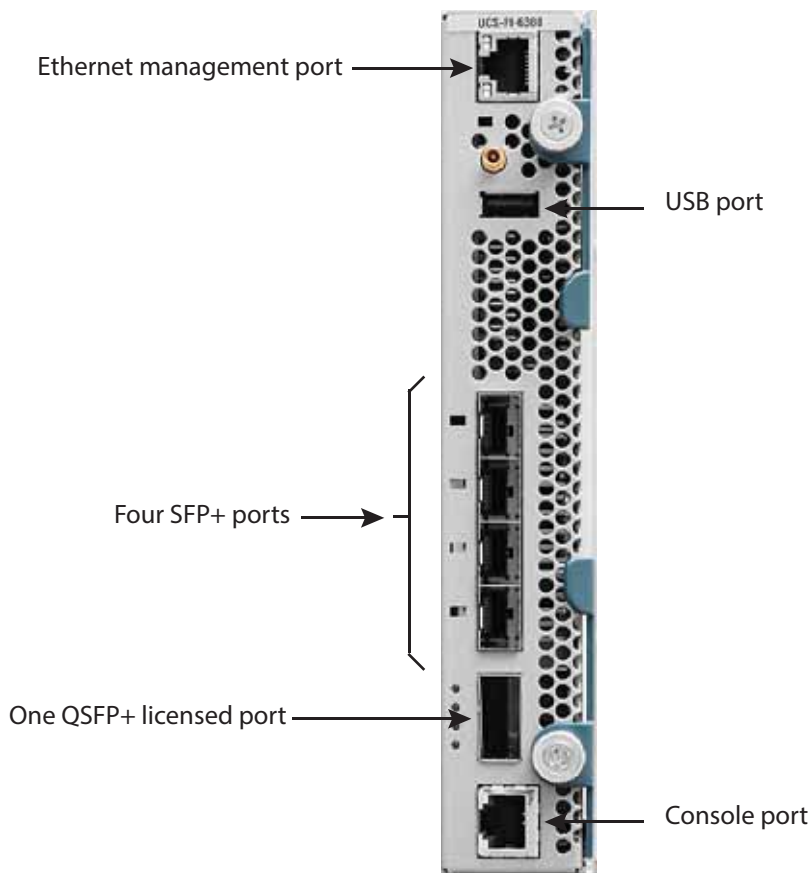

## BASE CHASSIS STANDARD CAPABILITIES and FEATURES

*Table 3* lists the capabilities and features of the base 5108 chassis. Details about how to configure the chassis for a particular feature or capability are provided in *CONFIGURING the CHASSIS on page 12*.

Table 3 Capabilities and Features

Capability/Feature	Description
Management by Cisco UCS Manager	<ul style="list-style-type: none"> <li>■ Reduces TCO by removing management modules from the chassis, making the chassis stateless, and UCS systems management inherently scalable</li> <li>■ Provides a single, highly available management domain for all system chassis, reducing administrative tasks through automated service profile configuration</li> </ul>
Unified fabric	Decreases TCO by reducing the number of network interface cards (NICs), host bus adapters (HBAs), switches, and cables needed
Support for up to two Cisco UCS 2100 or 2200 Series Fabric Extenders	<ul style="list-style-type: none"> <li>■ Eliminates switches from the chassis along with complex configuration and management of those switches, allowing a system to scale without adding complexity and cost</li> <li>■ Allows use of two fabric extenders for redundancy or aggregation of bandwidth</li> <li>■ Enables bandwidth scaling based on application needs; blades can be configured for 1.25 Gbps to 10 Gbps or more</li> </ul>
Support for up to two Cisco UCS 6324 Fabric Interconnects that connect directly to an external switch	<ul style="list-style-type: none"> <li>■ Allows use of up to two internal 6324 fabric interconnects for redundancy or aggregation of bandwidth</li> <li>■ The 6324 Fabric Interconnect combines the Fabric Extender and Fabric Interconnect functions into one plug-in module, and allows direct connection to an external switch.</li> </ul>
Auto-discovery	Requires no configuration; like all components in the Cisco Unified Computing System, chassis are automatically recognized and configured by Cisco UCS Manager and its service profiles and service profile groups
High-performance mid-plane	<ul style="list-style-type: none"> <li>■ Provides investment protection</li> <li>■ Supports up to 2x 40 Gbit Ethernet links to each half-width blade slot or up to 4x 40 Gbit links to each full-width slot</li> <li>■ Provides 8 blades with 1.2 terabits (Tb) of available Ethernet throughput for future I/O requirements. Note that the UCS 6324 FI supports only 512 Gbps.</li> <li>■ Provides reconfigurable chassis to accommodate a variety of form factors and functions</li> </ul>
Redundant hot-swappable power supplies and fans	<ul style="list-style-type: none"> <li>■ Provides high availability in multiple configurations</li> <li>■ Provides uninterrupted service during maintenance</li> </ul>

Table 3 Capabilities and Features (*continued*)

Capability/Feature	Description
Hot-swappable blade servers and fabric extenders	Provides uninterrupted service during maintenance and server deployment
Comprehensive monitoring	<ul style="list-style-type: none"> <li>■ Provides extensive environmental monitoring on each chassis</li> <li>■ Allows use of user thresholds to optimize environmental management of the chassis</li> </ul>
Thermal efficiencies	The Chassis Management Controller (CMC) monitors all the temperature sensors and regulates fan speeds to maintain the airflow at the minimum needed to cool the system. The open backplane and deep plenum allow air to be directed across the blades to ensure cooling is directed where it is needed most.
Tool-free installation	<ul style="list-style-type: none"> <li>■ Requires no specialized tools for chassis installation</li> <li>■ Provides mounting rails for easy installation and servicing</li> </ul>
Mixed blade configurations	The UCS 5108 Server Chassis can accommodate a maximum of 8 half-width sever blades or 4 full-width server blades or any combinations of the two sizes that will fit in the chassis.
UCS Manager	If a blade server using a v2 CPU (Ivy Bridge) is installed in the 5108 Server Chassis, the chassis must be controlled with UCS Manager (UCSM) version 2.2 or later.

## CONFIGURING the CHASSIS

Follow these steps to configure the Cisco UCS 5108 chassis:

- *STEP 1 VERIFY BASE CHASSIS SKU, page 13*
- *STEP 2 SELECT FABRIC I/O EXTENDERS, page 15*
- *STEP 3 SELECT FABRIC INTERCONNECTS, page 16*
- *STEP 4 CHOOSE ADDITIONAL COMPONENTS (OPTIONAL), page 17*
- *STEP 5 CHOOSE POWER SUPPLIES, page 21*
- *STEP 6 SELECT AC POWER CORD(s), page 22*
- *STEP 7 CHOOSE OPERATING SYSTEM (OPTIONAL), page 23*
- *STEP 8 CHOOSE SERVICE and SUPPORT LEVEL, page 24*
- *SUPPLEMENTAL MATERIAL on page 29*

## STEP 1 VERIFY BASE CHASSIS SKU

Verify the product ID (PID) of the base 5108 chassis as shown in [Table 4](#). Note that you can order either an AC-powered, -48 VDC-powered, or high-voltage DC (200 VDC–380 VDC) powered version of the chassis.

Table 4 PID of the Base UCS Mini Chassis

Product ID (PID)	Description	Usage
UCSB-5108-AC2	UCS 5108 Blade Server AC2 Chassis, 0 PSU/8 fans/0 FEX	Used as part of the N20-Z0001 and UCS-MINI-Z0001 bundle to include Fabric Interconnects, blades, power supplies (PSUs) and fabric extender (FEX) modules as a configured system.
UCSB-5108-AC2-UPG	UCS 5108 Blade Server AC2 Chassis, 0 PSU/8 fans/0 FEX	Can only be used to order a chassis configured with blades, power supplies, and FEX modules. May not be used to order an empty chassis.
UCSB-5108-AC2=	UCS 5108 Blade Server AC2 Chassis, 0 PSU/8 fans/0 FEX	Used to order an empty chassis, cannot be configured with blades. Power supplies and FEX modules may be installed.
UCSB-5108-DC2	UCS 5108 Blade Server DC2 Chassis/0 PSU/8 fans/0 FEX	Used as part of the N20-Z0001 and UCS-MINI-Z0001 bundle to include Fabric Interconnects, blades, power supplies (PSUs) and fabric extender (FEX) modules as a configured system.
UCSB-5108-DC2-UPG	UCS 5108 Blade Server DC2 Chassis/0 PSU/8 fans/0 FEX	Can only be used to order a chassis configured with blades, power supplies, and FEX modules. May not be used to order an empty chassis.
UCSB-5108-DC2=	UCS 5108 Blade Server DC2 Chassis/0 PSU/8 fans/0 FEX	Used to order an empty chassis, cannot be configured with blades. Power supplies and FEX modules may be installed.
UCSB-5108-HVDC	UCS 5108 Blade Chassis 200V-380V HVDC 0 PSU/8 fans/0 FEX	Used as part of the N20-Z0001 and UCS-MINI-Z0001 bundle to include Fabric Interconnects, blades, power supplies (PSUs) and fabric extender (FEX) modules as a configured system.
UCSB-5108-HVDC-UPG	UCS 5108 Blade Chassis 200V-380V HVDC 0 PSU/8 fans/0 FEX	Can only be used to order a chassis configured with blades, power supplies, and FEX modules. May not be used to order an empty chassis.
UCSB-5108-HVDC=	UCS 5108 Blade Chassis 200V-380V HVDC 0 PSU/8 fans/0 FEX	Used to order an empty chassis, cannot be configured with blades. Power supplies and FEX modules may be installed.

### Included with the chassis:

- N20-CAK: Chassis Accessory Kit, consisting of:
  - N20-CRMK2: One Rail kit that supports square-holed racks (or round hole racks with an optional adapter - see below)
  - N20-BKVM=: KVM local console connector dongle cable that connects to the front of any UCS blade server, and documentation
  - N20-FAN5: Eight redundant and hot-swappable fan modules

### Not included with the chassis (but may be ordered separately):

- N20-CRMK2=: Additional or spare rail kit for the Cisco 5108 chassis
- N20-CRMK2-RHA=: Round hole adapter kit (for threaded and non-threaded holes) for the rail kit (N20-CRMK2) included with the chassis.



NOTE: The adapter kit only works with the N20-CRMK2 rail kit

---

- N20-CBLKB1=: Blade slot blanking panel for UCS 5108/single slot
- N20-CDIVH=: Horizontal divider for UCS 5108
- N20-CDIVV=: Vertical divider for UCS 5108

### Caveats

---

- You must select either an AC, DC, or high-voltage version of the 5108 chassis.
- There is no mixing allowed of AC, DC, and high-voltage power supplies within the same 5108 chassis.

## STEP 2 SELECT FABRIC I/O EXTENDERS

The Fabric I/O Extender options are:

- Cisco UCS 2208XP
- Cisco UCS 2204XP
- Cisco UCS 2104XP

### Choose Fabric I/O Extenders

The available Fabric I/O Extenders are listed in [Table 5](#). Each Fabric I/O Extender connects to the Fabric Interconnect 6100 series modules by means of several ports of 10GbE and Fibre Channel over Ethernet (FCoE).

Table 5 Available Fabric I/O Extenders

Product ID (PID)	Fabric I/O Extender	Number of 10GbE/FCoE Ports to Fabric Interconnect	Number of Internal 10GbE/FCoE Ports	Total Chassis I/O per Fabric Extender
UCS-IOM-2208XP	2208XP	8	32	80 Gbs
UCS-IOM2208-16FET	Bundle that includes one 2208XP plus 16 Fabric Extender Transceivers (FETs) <sup>1</sup>	8	32	80 Gbs
UCS-IOM-2204XP	2204XP	4	16	40 Gbs
UCS-IOM2204-8FET	Bundle that includes one 2204XP plus 8 Fabric Extender Transceivers (FETs) <sup>1</sup>	4	16	40 Gbs
N20-I6584	2104XP	4	8	40 Gbs

Notes . . .

1. For more information on Fabric Extender bundles, see [Fabric Extender Bundles on page 55](#).

### Approved Configurations

- (1) Choose one or two identical Fabric I/O Extenders, or
- (2) Choose one or two identical Fabric Extender bundles (includes one Fabric Extender plus transceivers)

### Caveats

- You must select either one or two identical Fabric I/O Extenders or bundles.
- Do not use any Fabric Extender transceivers other than those that come in the bundles.
- You cannot combine a 6324 Fabric Interconnect and a Fabric Extender in the same chassis

### STEP 3 SELECT FABRIC INTERCONNECTS

The Fabric Interconnect options are:

- Cisco UCS 6324 Fabric Interconnect

#### Choose Fabric Interconnects

The available Fabric Interconnects are listed in [Table 6](#). Each Fabric Interconnect integrates the functions of a Fabric I/O Extender and Fabric Interconnect and connects directly to external Nexus switches by means of several ports of 10GbE and Fibre Channel over Ethernet (FCoE).

Table 6 Available Fabric Interconnects

Product ID (PID)	Fabric Interconnect	Number of Internal 10GbE/FCoE Ports	Number of 1Gb/10Gb FCoE Uplink Ports	Number of 40GbE/FCoE Scalability Ports <sup>1</sup>	Total Chassis I/O per Fabric Interconnect
UCS-FI-M-6324	UCS 6324 in-chassis FI with 1 x 40G QSFP+ expansion port, and 16 10G-KR links to servers	16	4	1	40 Gbs (one 40 GbE Port)

Notes . . .

1. The scalability port supports a QSFP+ breakout cable.

#### Approved Configurations

- (1) Choose one or two identical Fabric Interconnects

#### Caveats

- You must select either one or two identical Fabric Interconnects.
- You cannot combine a 6324 Fabric Interconnect and a Fabric Extender in the same chassis



## STEP 4 CHOOSE ADDITIONAL COMPONENTS (OPTIONAL)

A variety of optical and copper Small Form-Factor Pluggable (SFP) transceivers and copper twinax cables are available for use with the Fabric Extenders.

### Choose SFP+ Optical Transceivers

---

You can choose up to eight SFP+ optical transceivers for each 2208XP, or up to four for each 2204XP or 2104XP, as shown in [Table 7](#). You can alternatively choose up to four SFP+ optical transceivers for each 6324, as shown in [Table 7](#).

Table 7 SFP+ Transceivers

Product ID (PID)	PID Description
SFP-10G-SR	10GBASE-SR SFP Module
SFP-10G-LR	10GBASE-LR SFP Module
FET-10G	10G Line Extender for FEX

### Choose SFP Optical or Copper Transceivers

---

You may choose up to eight SFP optical or copper transceivers for each 2208XP, or up to four for each 2204XP or 2104XP, as shown in [Table 8](#). You can alternatively choose up to four SFP optical transceivers for each 6324, as shown in [Table 8](#).

Table 8 SFP Optical Transceivers

Product ID (PID)	PID Description
GLC-T	1 GbE copper SFP Module
GLC-SX-MM	1 GbE short range (550 m max) SFP Module
GLC-LH-SM	1 GbE long range (10 km max) SFP Module

## Choose Twinax Copper Cables

You can choose twinax copper cables of various lengths (from 1 to 10 meters) as shown in [Table 9](#). The two longer cables (7 and 10 meters) are active, which means that they contain active components within the SFP+ connector housing to improve signal quality. The ends of these cables are connectorized and plug directly into SFP receptacles.

Table 9 Twinax Copper Cables

Product ID (PID)	PID Description
SFP-H10GB-CU1M	10 G Base-CU SFP+, 1 meter (twinax cable)
SFP-H10GB-CU2M	10 G Base-CU SFP+, 2 meter (twinax cable)
SFP-H10GB-CU3M	10 G Base-CU SFP+, 3 meter (twinax cable)
SFP-H10GB-CU5M	10 G Base-CU SFP+, 5 meter (twinax cable)
SFP-H10GB-ACU7M	10 G Base-CU SFP+, 7 meter (twinax cable)
SFP-H10GB-ACU10M	10 G Base-CU SFP+, 10 meter (twinax cable)
SFP-10G-AOC1M	10GBASE Active Optical SFP+ Cable, 1M
SFP-10G-AOC2M	10GBASE Active Optical SFP+ Cable, 2M
SFP-10G-AOC3M	10GBASE Active Optical SFP+ Cable, 3M
SFP-10G-AOC5M	10GBASE Active Optical SFP+ Cable, 5M
SFP-10G-AOC7M	10GBASE Active Optical SFP+ Cable, 7M
SFP-10G-AOC10M	10GBASE Active Optical SFP+ Cable, 10M

## Choose QSFP+ Copper/Optical Transceivers

The 40-Gigabit QSFP+ transceiver module is a hot-swappable, parallel fiber-optical module with four independent optical transmit and receive channels. These channels can terminate in another 40-Gigabit QSFP+ transceiver, or the channels can be broken out to four separate 10-Gigabit SFP+ transceivers. The QSFP+ transceiver module connects the electrical circuitry of the system with either a copper or an optical external network. The transceiver is used primarily in short reach applications in switches, routers, and data center equipment where it provides higher density than SFP+ modules. See the following link for more details:

[http://www.cisco.com/c/en/us/td/docs/interfaces\\_modules/transceiver\\_modules/installation/note/OL\\_24862.html#wp44860](http://www.cisco.com/c/en/us/td/docs/interfaces_modules/transceiver_modules/installation/note/OL_24862.html#wp44860)

You may choose one QSFP+ copper/optical transceiver for each 6324, as shown in [Table 10](#).

Table 10 QSFP+ Copper/Optical Transceivers

Product ID (PID)	PID Description
QSFP-4SFP10G-CU5M	40GBASE-CR4 QSFP+ to four 10GBASE-CU SFP+ direct attach breakout cable assembly, 5 meter passive
QSFP-4SFP10G-CU3M	40GBASE-CR4 QSFP+ to four 10GBASE-CU SFP+ direct attach breakout cable assembly, 3 meter passive
QSFP-4SFP10G-CU1M	40GBASE-CR4 QSFP+ to four 10GBASE-CU SFP+ direct attach breakout cable assembly, 1 meter passive
QSFP-40G-SR4	40GBASE-SR4, 4 lanes, 850 nm MMF QSFP transceiver nodule with MPO connector
QSFP-4x10G-AC7M	40GBASE-CR4 QSFP+ to four 10GBASE-CU SFP+ direct attach breakout cable assembly, 7 meter active
QSFP-4x10G-AC10M	40GBASE-CR4 QSFP+ to four 10GBASE-CU SFP+ direct attach breakout cable assembly, 10 meter active

#### Choose QSFP+ Port License

In order to use the QSFP+ port, a license must be added. See [Table 11](#).

Table 11 QSFP+ Port License

Product ID (PID)	PID Description
UCS-6324-40G	Mini FI License for 40G Scalability Port

#### Choose Fibre Channel SFPs for the 6324

Choose Fibre channel SFPs as needed for the 6324 from [Table 12](#).

Table 12 Fibre Channel SFP Transceivers

Product ID (PID)	PID Description
DS-SFP-FC4G-SW	4 Gbps Fibre Channel-SW SFP, LC connector
DS-SFP-FC8G-SW	8-Gbps Fibre Channel SW SFP+, LC connector

#### Approved Configurations

(1) Choose the number of transceivers or copper twinax cables according to the number of Fabric Extender or Fabric Interconnect ports that are active that or will be become active in the future.

## Caveats

---

- You should order enough SFPs, QSFPs, and cables to accommodate your maximum foreseeable needs.
- If you selected a QSFP+ transceiver, make sure you choose a QSFP+ port license.
- For the 6324, observe the following:
  - The maximum number of SFP+ transceivers, SFP optical transceivers, copper transceivers, or twinax cables must be less than or equal to four. A minimum of one of these must be installed for the 6324 to have network connectivity.
  - The maximum number of Fibre Channel SFPs must be less than or equal to three. The reason for this is that at least one SFP+ port on the 6324 must be free so the 6324 can connect to a network.

## STEP 5 CHOOSE POWER SUPPLIES

The 5108 chassis accommodates up to four power supplies.

### Choose Power Supplies

---

The available power supplies are listed in [Table 13](#).

Table 13 Available Power Supplies

Product ID (PID)	PID Description
UCSB-PSU-2500ACDV	2500 W Platinum AC Hot Plug Power Supply - DV
UCSB-PSU-2500DC48	2500 W DC -48 V power supply
UCSB-PS-2500HVDC	2500 W DC high voltage (200 - 380 VDC) DC power supply

---

### Approved Configurations

---

(1) Choose from 2 to 4 power supplies

### Caveats

---

- Do not mix AC, DC, and high-voltage power supplies
- Use only a -48 VDC power supply in a -48 VDC chassis
- Use only an HVDC power supply in an HVDC Chassis
- Use only an AC power supply in an AC chassis

## STEP 6 SELECT AC POWER CORD(s)

Select the appropriate AC power cords listed in [Table 14](#). You may select up to 4 power cords.

Table 14 Available Power Cords

Product ID (PID)	PID Description	Comment
CAB-AC-16A-AUS	16A, 250 VAC	Australia
UCSB-CABL-C19-BRZ	16A, 250 VAC	Brazil
CAB-AC16A-CH	16A, 250 VAC	China
CAB-AC-2500W-EU	16A, 250 VAC	Europe
CAB-AC-2500W-INT	16A, 250 VAC	International
CAB-AC-2500W-ISRL	16A, 250 VAC	Israel
CAB-US620P-C19-US	16A, 250 VAC	NEMA 6-20P
CAB-AC-C6K-TWLK	20A, 250 VAC (twist-lock)	NEMA L6-20
CAB-ACS-16	16A, 250 VAC	Switzerland
CAB-C19-CBN	16A, 250 VAC	Jumper cord C19/C20
CAB-US515P-C19-US	15A, 125 VAC NEMA 5-15 to IEC-C19 13ft US	USA
CAB-US520-C19-US	20A, 125 VAC NEMA 5-20 to IEC-C19 14ft US	USA

## STEP 7 CHOOSE OPERATING SYSTEM (OPTIONAL)

Several operating systems are available from which to choose. Choose one of the operating systems listed in [Table 15](#).

Table 15 Operating Systems

Product ID (PID)	PID Description
SUSE Linux Enterprise Server	
SLES-11	SLES 11 media only (multilingual)
SLES-CA-1A	SLES, 1-year subscription, services required, no media
SLES-CA-3A	SLES, 3-year subscription, services required, no media

## STEP 8 CHOOSE SERVICE and SUPPORT LEVEL

A variety of service options are available, as described in this section.

### Unified Computing Warranty, No Contract

If you have noncritical implementations and choose to have no service contract, the following coverage is supplied:

- Three-year parts coverage.
- Next business day (NBD) onsite parts replacement eight hours a day, five days a week.
- 90-day software warranty on media.
- Ongoing downloads of BIOS, drivers, and firmware updates.
- UCSM updates for systems with Unified Computing System Manager. These updates include minor enhancements and bug fixes that are designed to maintain the compliance of UCSM with published specifications, release notes, and industry standards.

### SMARTnet for UCS

For support of the entire Unified Computing System, Cisco offers the Cisco SMARTnet for UCS Service. This service provides expert software and hardware support to help sustain performance and high availability of the unified computing environment. Access to Cisco Technical Assistance Center (TAC) is provided around the clock, from anywhere in the world.

For the 5108 chassis, there is Smart Call Home, which provides proactive, embedded diagnostics and real-time alerts. For systems that include Unified Computing System Manager, the support service includes downloads of UCSM upgrades. The Cisco SMARTnet for UCS Service includes flexible hardware replacement options, including replacement in as little as two hours. There is also access to Cisco's extensive online technical resources to help maintain optimal efficiency and uptime of the unified computing environment. You can choose a desired service listed in [Table 16](#).

Table 16 Cisco SMARTnet for UCS Service

Service SKU	On Site?	Description
<b>AC Chassis</b>		
CON-PREM-6508AC2	Yes	ONSITE 24X7X2 5108 AC Chassis
CON-OSP-6508AC2	Yes	ONSITE 24X7X4 5108 AC Chassis
CON-OSE-6508AC2	Yes	ONSITE 8X5X4 5108 AC Chassis
CON-OS-6508AC2	Yes	ONSITE 8X5XNBD 5108 AC Chassis
CON-S2P-6508AC2	No	SMARTNET 24X7X2 5108 AC Chassis
CON-SNTP-6508AC2	No	SMARTNET 24X7X4 5108 AC Chassis
CON-SNTE-6508AC2	No	SMARTNET 8X5X4 5108 AC Chassis
CON-SNT-6508AC2	No	SMARTNET 8X5XNBD 5108 AC Chassis



Table 16 Cisco SMARTnet for UCS Service (continued)

Service SKU	On Site?	Description
<b>DC Chassis</b>		
CON-PREM-6508DC2	Yes	ONSITE 24X7X2 5108 DC Chassis
CON-OSP-6508DC2	Yes	ONSITE 24X7X4 5108 DC Chassis
CON-OSE-6508DC2	Yes	ONSITE 8X5X4 5108 DC Chassis
CON-OS-6508DC2	Yes	ONSITE 8X5XNBD 5108 DC Chassis
CON-S2P-6508DC2	No	SMARTNET 24X7X2 5108 DC Chassis
CON-SNTP-6508DC2	No	SMARTNET 24X7X4 5108 DC Chassis
CON-SNTE-6508DC2	No	SMARTNET 8X5X4 5108 DC Chassis
CON-SNT-6508DC2	No	SMARTNET 8X5XNBD 5108 DC Chassis

#### SMARTnet for UCS Hardware Only Service

For faster parts replacement than is provided with the standard Cisco Unified Computing System warranty, Cisco offers the Cisco SMARTnet for UCS Hardware Only Service. You can choose from two levels of advanced onsite parts replacement coverage in as little as four hours. SMARTnet for UCS Hardware Only Service provides remote access any time to Cisco support professionals who can determine if a return materials authorization (RMA) is required. You can choose a service listed in [Table 17](#).

Table 17 SMARTnet for UCS Hardware Only Service

Service SKU	Service Level GSP	On Site?	Description
<b>AC Chassis</b>			
CON-UCW7-6508AC2	UCW7	Yes	UC PLUS 24X7X4OS 5108 AC Chassis
CON-UCW5-6508AC2	UCW5	Yes	UC PLUS 8X5XNBDOS 5108 AC Chassis
<b>DC Chassis</b>			
CON-UCW7-6508DC2	UCW7	Yes	UC PLUS 24X7X4OS 5108 DC Chassis
CON-UCW5-6508DC2	UCW5	Yes	UC PLUS 8X5XNBDOS 5108 DC Chassis

### Unified Computing Partner Support Service

Cisco Partner Support Service (PSS) is a Cisco Collaborative Services service offering that is designed for partners to deliver their own branded support and managed services to enterprise customers. Cisco PSS provides partners with access to Cisco's support infrastructure and assets to help them:

- Expand their service portfolios to support the most complex network environments
- Lower delivery costs
- Deliver services that increase customer loyalty

Partner Unified Computing Support Options enable eligible Cisco partners to develop and consistently deliver high-value technical support that capitalizes on Cisco intellectual assets. This helps partners to realize higher margins and expand their practice.

Partner Unified Computing Support Options are available to Cisco PSS partners. For additional information, see the following URL:

[www.cisco.com/go/partnerucssupport](http://www.cisco.com/go/partnerucssupport)

The two Partner Unified Computing Support Options include:

- Partner Support Service for UCS
- Partner Support Service for UCS Hardware Only

Partner Support Service for UCS provides hardware and software support, including triage support for third party software, backed by Cisco technical resources and level three support. See [Table 18](#).

Table 18 Partner Support Service for UCS

Service SKU	Service Level GSP	On Site?	Description
<b>AC Chassis</b>			
CON-PSJ1-6508AC2	PSJ1	No	UCS SUPP PSS 8X5XNBD 5108 AC Chassis
CON-PSJ2-6508AC2	PSJ2	No	UCS SUPP PSS 8X5X4 5108 AC Chassis
CON-PSJ3-6508AC2	PSJ3	No	UCS SUPP PSS 24X7X4 5108 AC Chassis
CON-PSJ4-6508AC2	PSJ4	No	UCS SUPP PSS 24X7X2 5108 AC Chassis
CON-PSJ6-6508AC2	PSJ6	Yes	UCS SUPP PSS 8x5x4 Onsite 5108 AC Chassis
CON-PSJ7-6508AC2	PSJ7	Yes	UCS SUPP PSS 24X7X4 Onsite 5108 AC Chassis

Table 18 Partner Support Service for UCS (*continued*)

Service SKU	Service Level GSP	On Site?	Description
<b>DC Chassis</b>			
CON-PSJ1-6508DC2	PSJ1	No	UCS SUPP PSS 8X5XNBD 5108 DC Chassis
CON-PSJ2-6508DC2	PSJ2	No	UCS SUPP PSS 8X5X4 5108 DC Chassis
CON-PSJ3-6508DC2	PSJ3	No	UCS SUPP PSS 24X7X4 5108 DC Chassis
CON-PSJ4-6508DC2	PSJ4	No	UCS SUPP PSS 24X7X2 5108 DC Chassis
CON-PSJ6-6508DC2	PSJ6	Yes	UCS SUPP PSS 8x5x4 Onsite 5108 DC Chassis
CON-PSJ7-6508DC2	PSJ7	Yes	UCS SUPP PSS 24X7X4 Onsite 5108 DC Chassis
CON-PSJ8-6508DC2	PSJ8	Yes	UCS SUPP PSS 24X7X2 Onsite 5108 DC Chassis

Partner Support Service for UCS Hardware Only provides customers with replacement parts in as little as two hours. See [Table 19](#).

Table 19 Partner Support Service for UCS (Hardware Only)

Service SKU	Service Level GSP	On Site?	Description
<b>AC Chassis</b>			
CON-PSW2-6508AC2	PSW2	No	UCS W PL PSS 8X5X4 5108 AC Chassis
CON-PSW3-6508AC2	PSW3	No	UCS W PL PSS 24X7X4 5108 AC Chassis
CON-PSW4-6508AC2	PSW4	No	UCS W PL PSS 24X7X2 5108 AC Chassis
CON-PSW6-6508AC2	PSW6	Yes	UCS HW ONLY PSS 8x5x4 Onsite 5108 AC Chassis
CON-PSW7-6508AC2	PSW7	Yes	UCS HW ONLY PSS 24x7x4 Onsite 5108 AC Chassis

Table 19 Partner Support Service for UCS (Hardware Only) *(continued)*

Service SKU	Service Level GSP	On Site?	Description
<b>DC Chassis</b>			
CON-PSW2-6508DC2	PSW2	No	UCS W PL PSS 8X5X4 5108 DC Chassis
CON-PSW3-6508DC2	PSW3	No	UCS W PL PSS 24X7X4 5108 DC Chassis
CON-PSW4-6508DC2	PSW4	No	UCS W PL PSS 24X7X2 5108 DC Chassis
CON-PSW6-6508DC2	PSW6	Yes	UCS HW ONLY PSS 8x5x4 Onsite 5108 DC Chassis
CON-PSW7-6508DC2	PSW7	Yes	UCS HW ONLY PSS 24x7x4 Onsite 5108 DC Chassis

For more service and support information, see the following URL:

[http://www.cisco.com/en/US/services/ps2961/ps10312/Unified\\_Computing\\_Services\\_Overview.pdf](http://www.cisco.com/en/US/services/ps2961/ps10312/Unified_Computing_Services_Overview.pdf)

For a complete listing of available services for Cisco Unified Computing System, see this URL:

[http://www.cisco.com/en/US/products/ps10312/serv\\_group\\_home.html](http://www.cisco.com/en/US/products/ps10312/serv_group_home.html)

# SUPPLEMENTAL MATERIAL

## System Overview

The Cisco Unified Computing System™ (Cisco UCS™) is a next-generation data center platform that unites compute, network, storage access, and virtualization resources into a cohesive system designed to reduce total cost of ownership (TCO) and increase business agility. The system integrates a low-latency, lossless 10 Gigabit Ethernet unified network fabric with enterprise-class, x86-architecture servers. The system is an integrated, scalable, multichassis platform in which all resources participate in a unified management domain.

## Connectivity Between Blades and Fabric Extenders

Figure 9 is a system diagram showing a 5108 chassis with Fabric Extenders connected in a system.

Figure 9 System Diagram (5108 Chassis with Fabric Extenders)

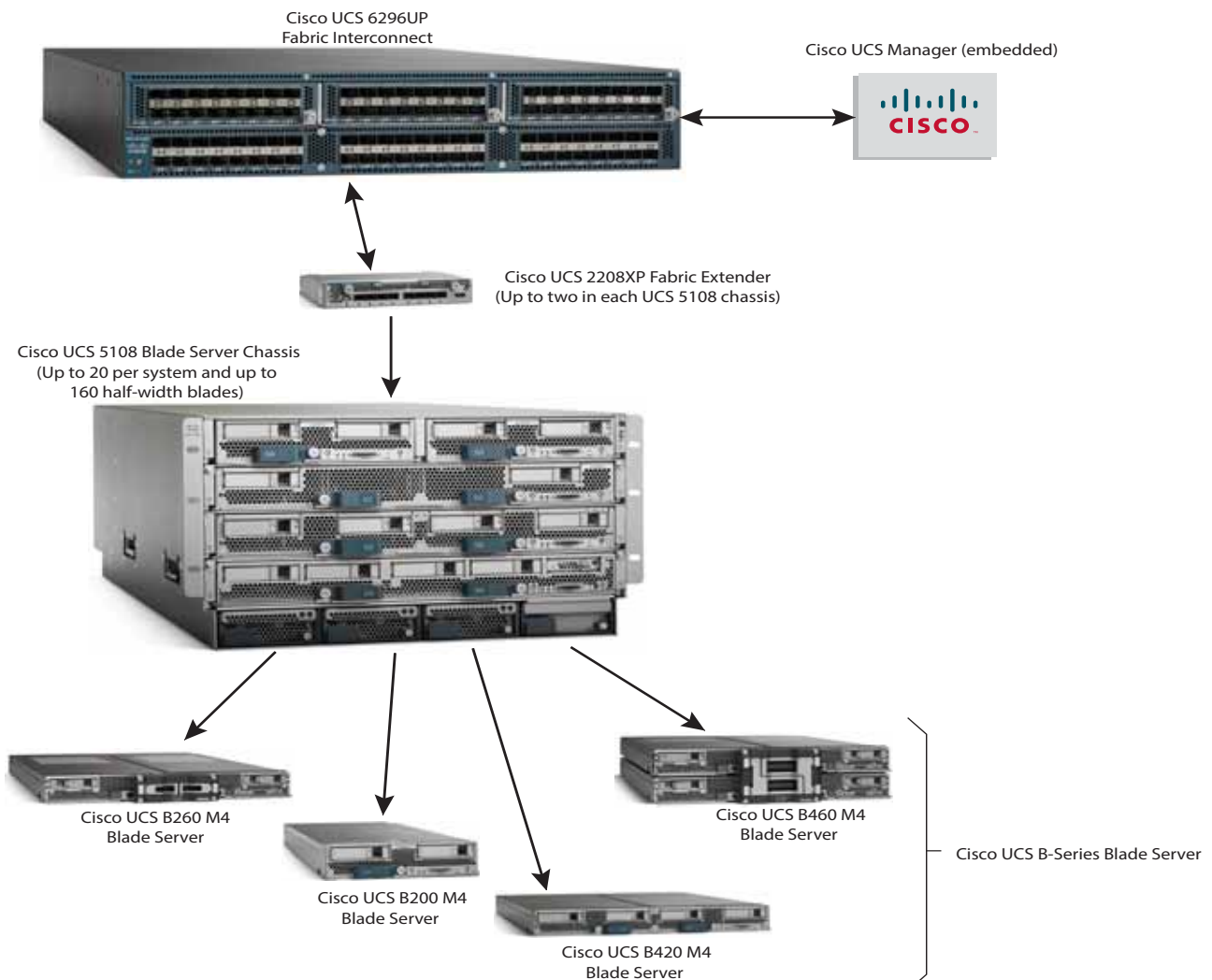

Cisco UCS Fabric Extenders bring the unified fabric into the blade server enclosure, providing multiple 10 Gigabit Ethernet connections between blade servers and the fabric interconnect, simplifying diagnostics, cabling, and management.

The Fabric Extenders extend the I/O fabric between the Cisco UCS 6100 and 6200 Series Fabric Interconnects and the Cisco UCS 5108 Blade Server Chassis, enabling a lossless and deterministic Fibre Channel over Ethernet (FCoE) fabric to connect all blades and chassis together. Since the fabric extender is similar to a distributed line card, it does not perform any switching and is managed as an extension of the fabric interconnects. This approach removes switching from the chassis, reducing overall infrastructure complexity and enabling Cisco UCS to scale to many chassis without multiplying the number of switches needed, reducing TCO and allowing all chassis to be managed as a single, highly available management domain.

The Fabric Extenders also manage the chassis environment (the power supply and fans as well as the blades) in conjunction with the fabric interconnect. Therefore, separate chassis management modules are not required.

The Fabric Extenders fit into the back of the Cisco UCS 5108 chassis. Each Cisco UCS 5108 chassis can support up to two fabric extenders, allowing increased capacity and redundancy.

Connectivity between each unique blade and the Fabric Extenders varies according to the type of blade, its available adapter card slots, and the type of card plugged into each slot. See the individual blade server spec sheets for detailed connectivity information and connectivity diagrams at this link:

[http://www.cisco.com/en/US/products/ps10280/products\\_data\\_sheets\\_list.html](http://www.cisco.com/en/US/products/ps10280/products_data_sheets_list.html)

The following sections show generally how the various blade connect to the Fabric Extenders.

## B200 M2/B230 M1/M2 Connectivity (Half-Width Blades with One Mezzanine Slot)

Figure 10 shows in general how the B200 M2/B230 M1/M2 blade servers connect to the fabric extenders in the UCS 5108 chassis. Several cards are available for use in the card adapter slot (see Table 20 on page 32).

Figure 10 B200 M2/B230 M1/M2 to Fabric Extenders

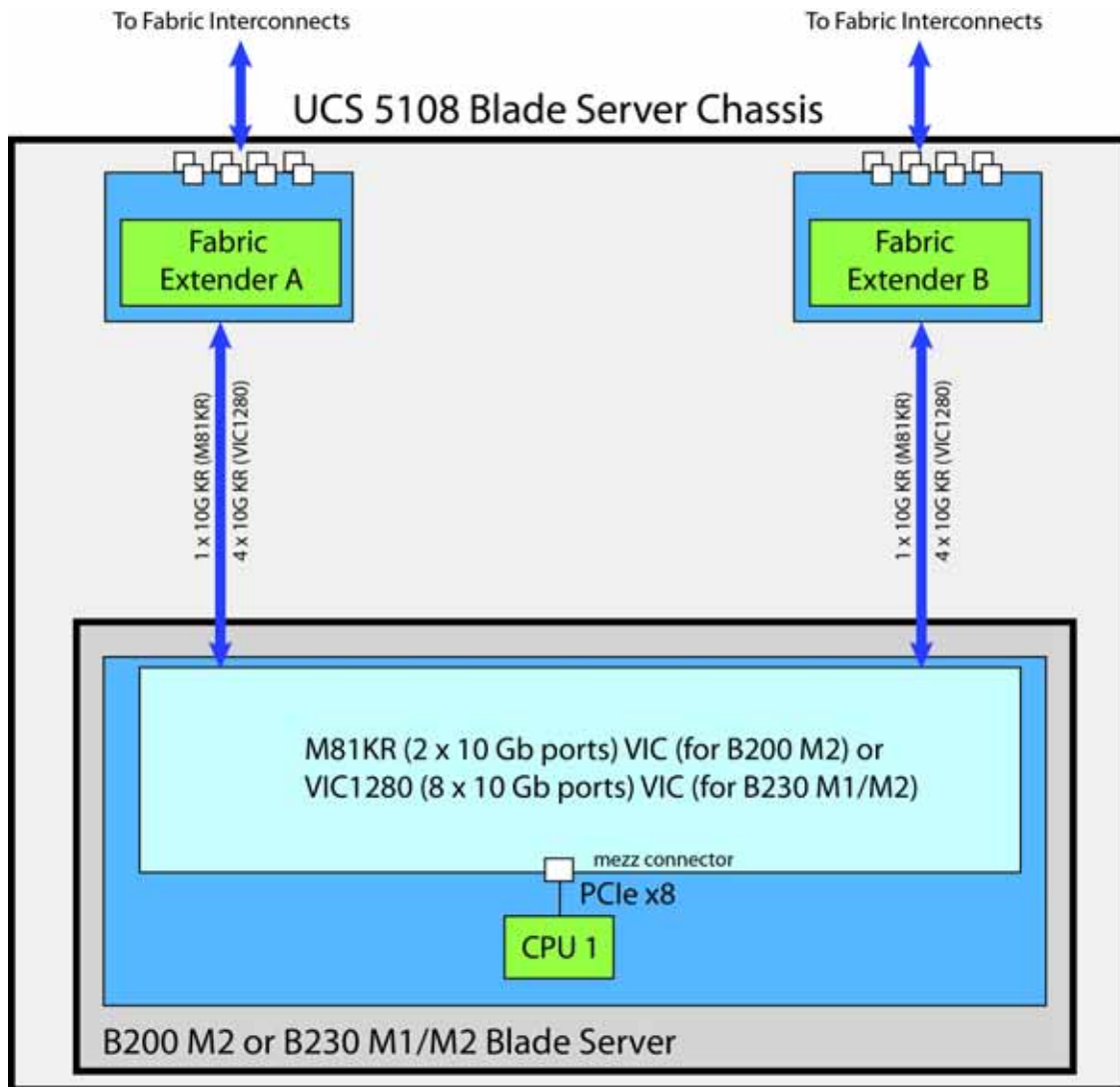

For the B200 M2/B230 M1/M2 blade servers, supported card adapter combinations are shown in [Table 20](#).

Table 20 Adapter Card Options

Fabric Extender Compatibility	Adapter in Mezzanine Connector	Ports <sup>1</sup>
<b>2208XP</b>		
2208XP	M81KR	2 x 10 Gb
2208XP	VIC 1280 <sup>2</sup>	8 x 10 Gb
2208XP	Cisco-certified mezzanine adapter <sup>3</sup>	2 x 10 Gb
<b>2204XP</b>		
2204XP	M81KR	2 x 10 Gb
2204XP	VIC 1280 <sup>2</sup>	4 x 10 Gb
2204XP	Cisco-certified mezzanine adapter <sup>3</sup>	2 x 10 Gb
<b>2104XP</b>		
2104 XP	M81KR	2 x 10 Gb
2104 XP	VIC 1280 <sup>2</sup>	2 x 10 Gb
2104XP	Cisco-certified mezzanine adapter <sup>3</sup>	2 x 10 Gb

Notes . . .

1. Cisco-designed adapters are capable of port channeling. A port channel bundles up to four individual interfaces into a group to provide increased bandwidth and redundancy. Port channeling also load balances traffic across these physical interfaces. The port channel stays operational as long as at least one physical interface within the port channel is operational. Cisco-certified adapters supplied by third-party vendors do not support port channeling. Port channeling is indicated with an oval drawn around several individual ports.
2. Available only on M2 and M3 servers (not available on M1 servers)
3. Cisco-certified mezzanine adapters are manufactured by third-party vendors and are certified by Cisco for use in the servers. For more information about supported Cisco-certified mezzanine adapters, see [http://www.cisco.com/en/US/docs/unified\\_computing/ucs/hw/chassis/install/blade.html#wp1010426](http://www.cisco.com/en/US/docs/unified_computing/ucs/hw/chassis/install/blade.html#wp1010426)

The general connectivity diagrams between the mezzanine adapter cards and the different fabric extenders are shown in [Figure 11 on page 33](#) through [Figure 13 on page 34](#).



Figure 11 B200 M2/B230 M1/M2 to 2208XP Fabric Extenders

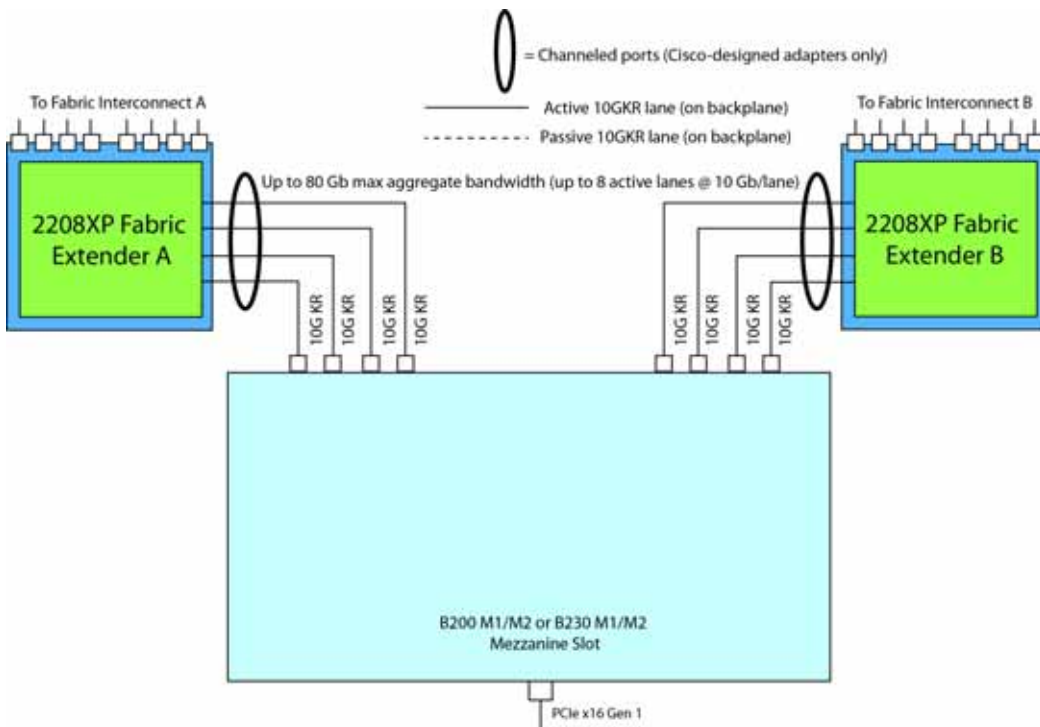

Figure 12 B200 M2/B230 M1/M2 2204XP Fabric Extenders

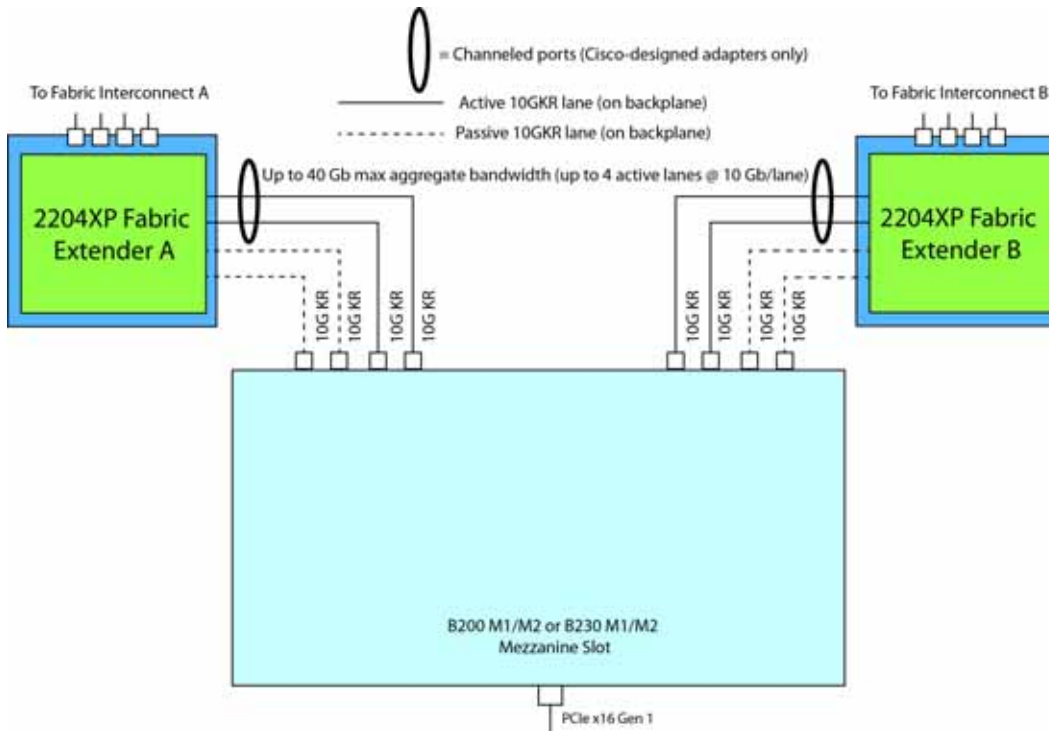
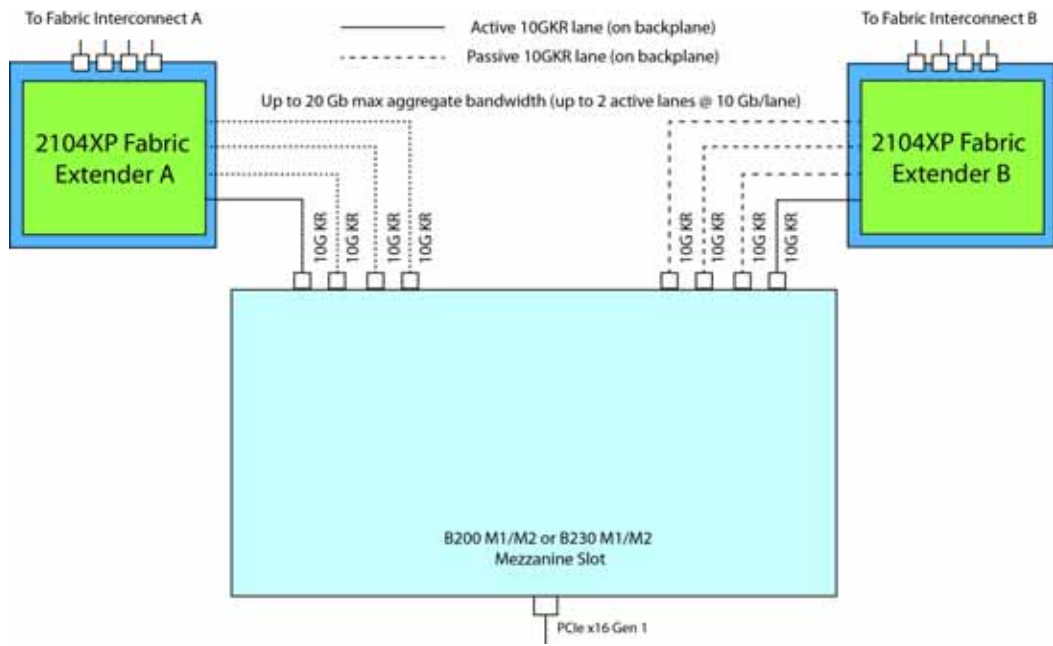

Figure 13 B200 M2/B230 M1/M2 to 2104XP Fabric Extenders



## B250 M2/B440 M1/M2 Connectivity (Full-Width Blades with Two Mezzanine Slots)

Figure 14 shows in general how the B250 M2/B440 M1/M2 blade servers connect to the fabric extenders in the UCS 5108 chassis. Several cards are available for use in the two card adapter slots (see Table 21 on page 36). Note that adapter slot 0 is on the right when the server is viewed from the rear and slot 1 is on the left.

Figure 14 B250 M2/B440 M1/M2 to Fabric Extenders

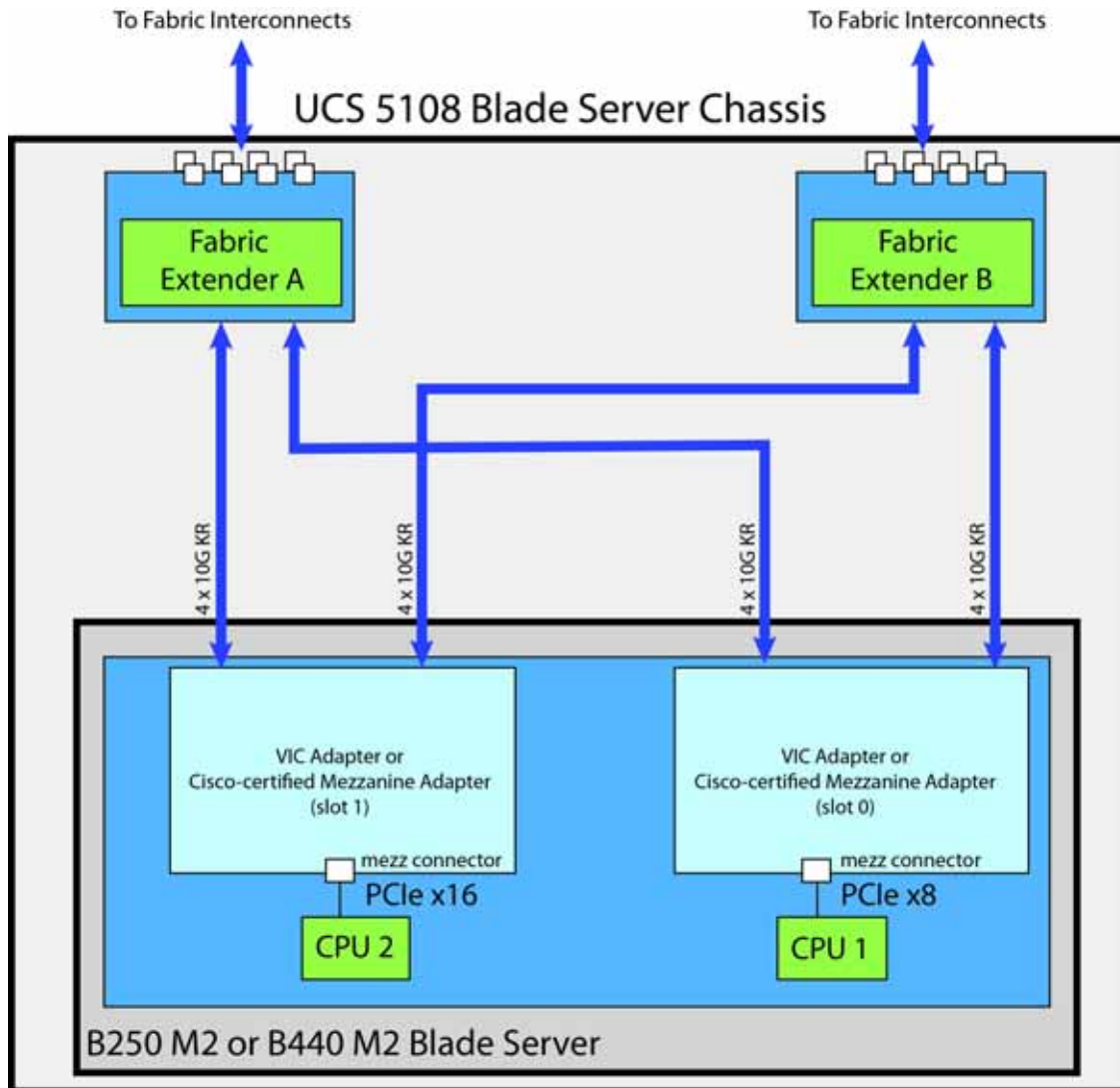

For the B250 M2/B440 M1/M2 blade servers, supported card adapter combinations are shown in [Table 21](#).

Table 21 Adapter Card Options

Fabric Extender Compatibility	Adapter in Slot 0	Adapter in Slot 1	Ports <sup>1</sup>
<b>2208XP</b>			
2208XP	M81KR	Unoccupied	2 x 10 Gb
2208XP	Cisco-certified mezzanine adapter <sup>2</sup>	Unoccupied	2 x 10 Gb
2208XP	VIC 1280 <sup>3</sup>	Unoccupied	8 x 10 Gb
2208XP	M81KR	Cisco-certified mezzanine adapter	4 x 10 Gb
2208XP	Cisco-certified mezzanine adapter	M81KR	4 x 10 Gb
2208XP	VIC 1280 <sup>3</sup>	Cisco-certified mezzanine adapter	10 x 10 Gb
2208XP	Cisco-certified mezzanine adapter	VIC 1280 <sup>3</sup>	10 x 10 Gb
2208XP	Cisco-certified mezzanine adapter	Cisco-certified mezzanine adapter	4 x 10 Gb
<b>2204XP</b>			
2204XP	M81KR	Unoccupied	2 x 10 Gb
2204XP	VIC 1280 <sup>3</sup>	Unoccupied	4 x 10 Gb
2204XP	Cisco-certified mezzanine adapter	Unoccupied	2 x 10 Gb
2204XP	M81KR	Cisco-certified mezzanine adapter	4 x 10 Gb
2204XP	Cisco-certified mezzanine adapter	M81KR	4 x 10 Gb
2204XP	VIC 1280 <sup>3</sup>	Cisco-certified mezzanine adapter	6 x 10 Gb
2204XP	Cisco-certified mezzanine adapter	VIC 1280 <sup>3</sup>	6 x 10 Gb
2204XP	Cisco-certified mezzanine adapter	Cisco-certified mezzanine adapter	4 x 10 Gb
<b>2104XP</b>			
2104 XP	M81KR	Unoccupied	2 x 10 Gb
2104 XP	Cisco-certified mezzanine adapter	Unoccupied	2 x 10 Gb
2104 XP	VIC 1280 <sup>3</sup>	Unoccupied	2 x 10 Gb
2104 XP	M81KR	Cisco-certified mezzanine adapter	2 x 10 Gb
2104 XP	Cisco-certified mezzanine adapter	M81KR	2 x 10 Gb
2104 XP	VIC 1280 <sup>3</sup>	Cisco-certified mezzanine adapter	2 x 10 Gb
2104 XP	Cisco-certified mezzanine adapter	VIC 1280 <sup>3</sup>	2 x 10 Gb

Table 21 Adapter Card Options (continued)

Fabric Extender Compatibility	Adapter in Slot 0	Adapter in Slot 1	Ports <sup>1</sup>
2104XP	Cisco-certified mezzanine adapter	Cisco-certified mezzanine adapter	2 x 10 Gb

Notes . . .

1. Cisco-designed adapters are capable of port channeling. A port channel bundles up to four individual interfaces into a group to provide increased bandwidth and redundancy. Port channeling also load balances traffic across these physical interfaces. The port channel stays operational as long as at least one physical interface within the port channel is operational. Cisco-certified adapters supplied by third-party vendors do not support port channeling. Port channeling is indicated with an oval drawn around several individual ports.
2. Cisco-certified mezzanine adapters are manufactured by third-party vendors and are certified by Cisco for use in the servers. For more information about supported Cisco-certified mezzanine adapters, see [http://www.cisco.com/en/US/docs/unified\\_computing/ucs/hw/chassis/install/blade.html#wp1010426](http://www.cisco.com/en/US/docs/unified_computing/ucs/hw/chassis/install/blade.html#wp1010426)
3. Available only on M2 and M3 servers (not available on M1 servers)

The general connectivity diagrams between the adapter cards and the different fabric extenders are shown in *Figure 15* through *Figure 17* on page 38.

Figure 15 B250 M2/B440 M1/M2 to 2208XP Fabric Extenders

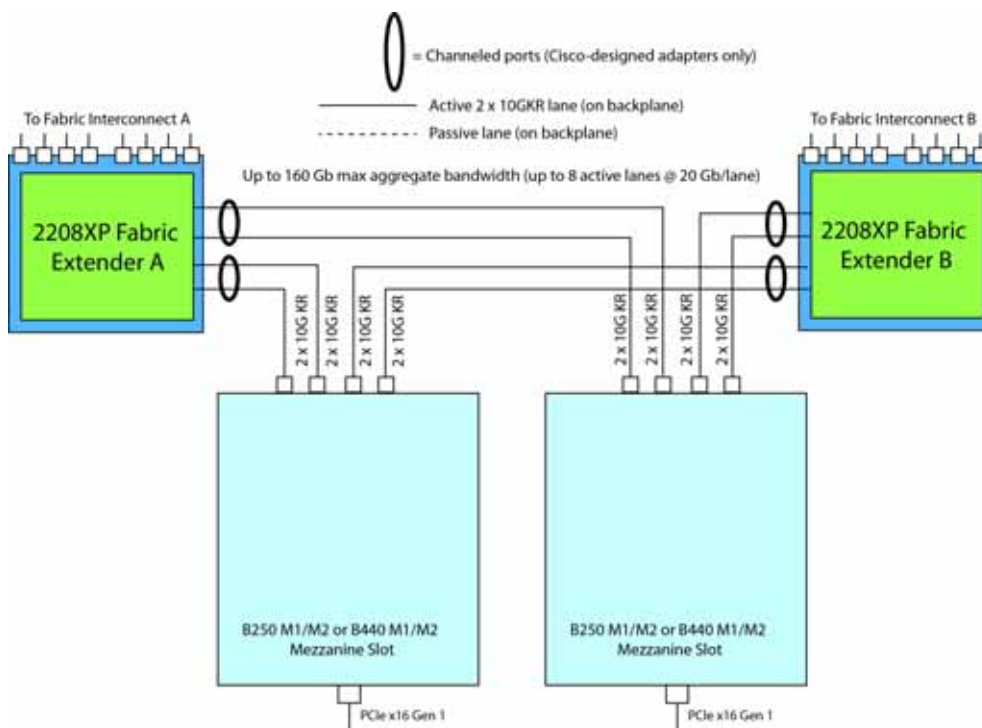

Figure 16 B250 M2/B440 M1/M2 to 2204XP Fabric Extenders

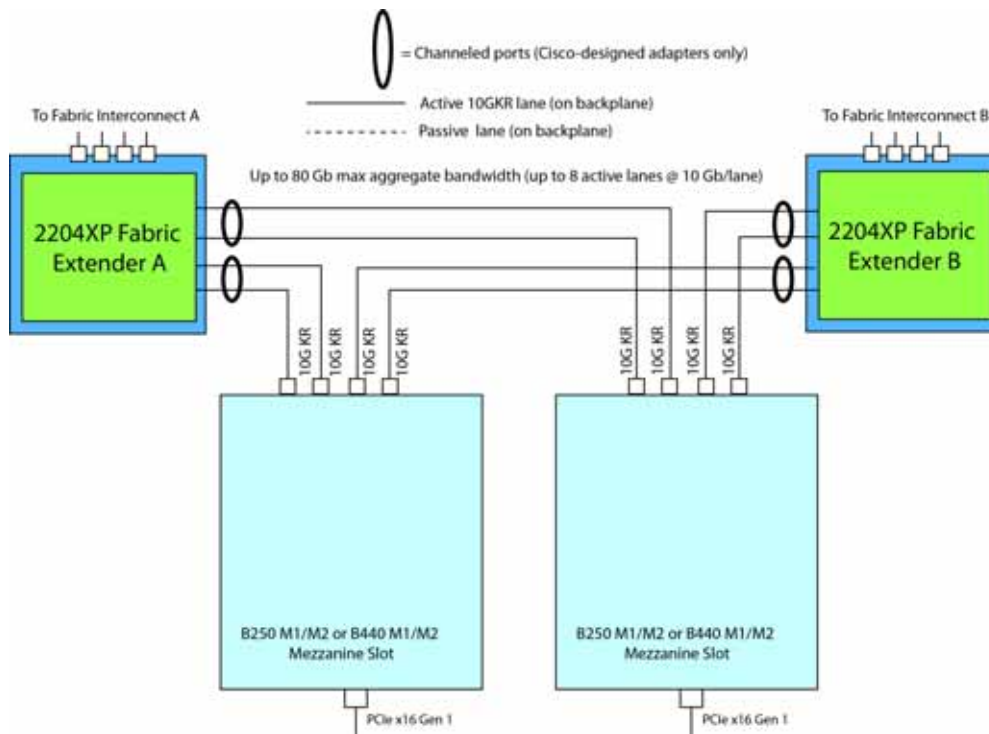
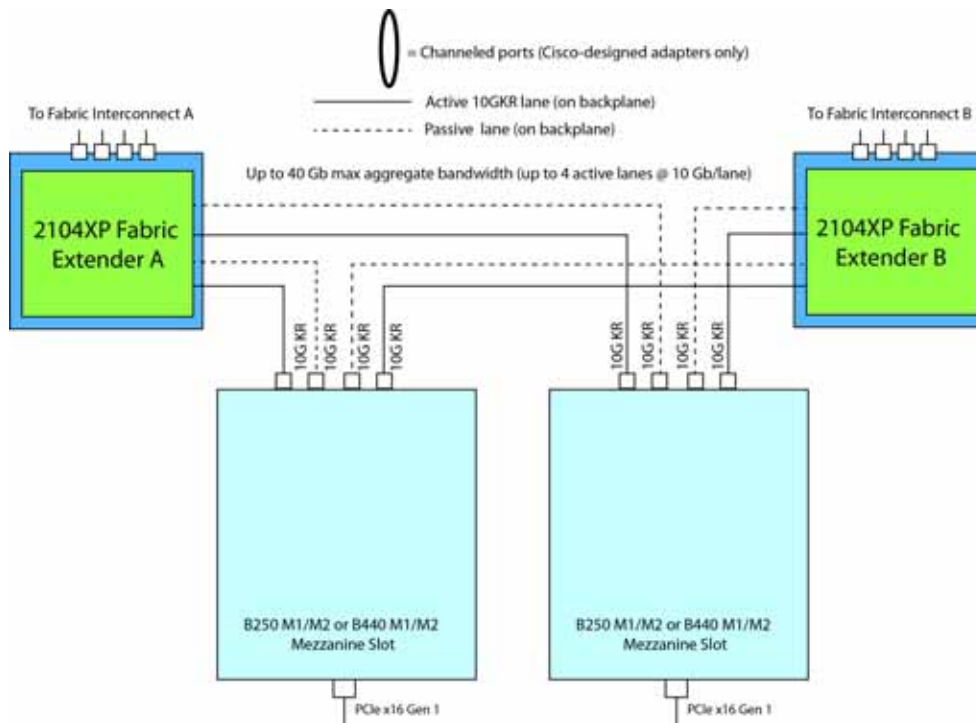

Figure 17 B250 M2/B440 M1/M2 to 2104XP Fabric Extenders



### B200 M3/M4 Connectivity (Half-Width Blades with Two Mezzanine Slots)

Figure 18 shows in general how the B200 M3/M4 blade servers connect to the fabric extenders in the UCS 5108 chassis. Several cards are available for use in the two card adapter slots (see Table 23 on page 44 and Table 24 on page 45).

Figure 18 B200 M3/M4 to Fabric Extenders

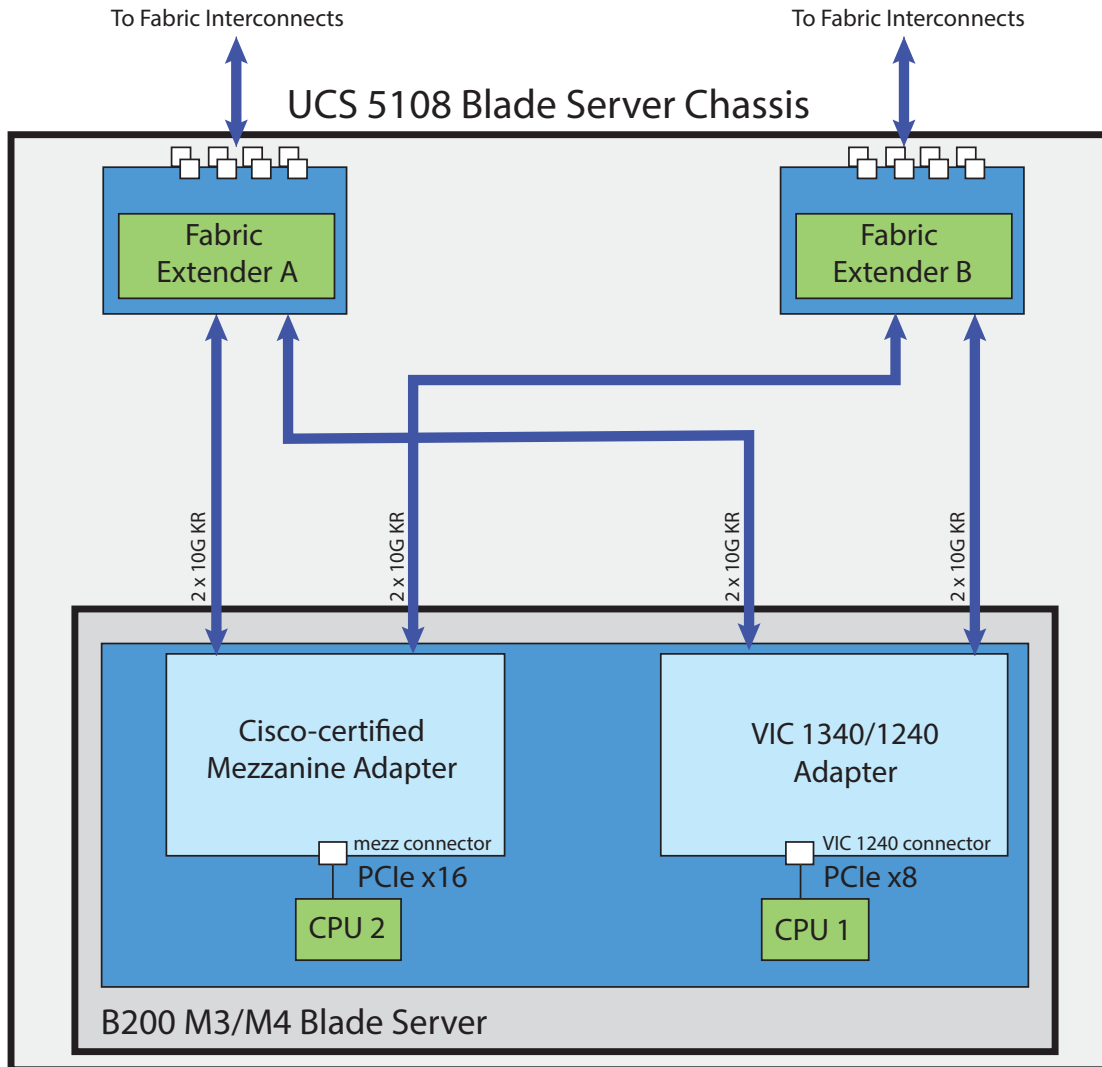

For the B200 M3/M4 blade server, supported card adapter combinations are shown in [Table 22](#).

Table 22 Adapter Card Options

Fabric Extender Compatibility	Adapter in VIC 1340/1240 Connector	Adapter in Mezzanine Connector	Ports <sup>1</sup>
<b>2208XP</b>			
2208XP	VIC 1340/1240	None	4 x 10 Gb
2208XP	VIC 1340/1240	VIC 1380/1280	8 x 10 Gb
2208XP	VIC 1340/1240	Cisco-certified mezzanine adapter <sup>2</sup>	6 x 10 Gb
2208XP	VIC 1340/1240	Port Expander Card for VIC 1340/1240	8 x 10 Gb
2208XP	None	Cisco-certified mezzanine adapter	2 x 10 Gb
<b>2204XP</b>			
2204XP	VIC 11340/240	None	2 x 10 Gb
2204XP	VIC 1340/1240	VIC 1380/1280	4 x 10 Gb
2204XP	VIC 1340/1240	Cisco-certified mezzanine adapter	4 x 10 Gb
2204XP	VIC 1340/1240	Port Expander Card for VIC 1340/1240	4 x 10 Gb
2204XP	None	Cisco-certified mezzanine adapter	2 x 10 Gb
<b>2104XP</b>			
2104XP	VIC 1340/1240	None <sup>3</sup>	2 x 10 Gb

Notes . . .

1. Cisco-designed adapters are capable of port channeling. A port channel bundles up to four individual interfaces into a group to provide increased bandwidth and redundancy. Port channeling also load balances traffic across these physical interfaces. The port channel stays operational as long as at least one physical interface within the port channel is operational. Cisco-certified adapters supplied by third-party vendors do not support port channeling. Port channeling is indicated with an oval drawn around several individual ports.
2. Cisco-certified mezzanine adapters are manufactured by third-party vendors and are certified by Cisco for use in the servers. For more information about supported Cisco-certified mezzanine adapters, see [http://www.cisco.com/en/US/docs/unified\\_computing/ucs/hw/chassis/install/blade.html#wp1010426](http://www.cisco.com/en/US/docs/unified_computing/ucs/hw/chassis/install/blade.html#wp1010426)
3. The 2104XP fabric extender is not compatible with any I/O card installed in the mezzanine connector.

The general connectivity diagrams between the adapter cards and the different fabric extenders are shown in [Figure 19 on page 41](#) through [Figure 21 on page 42](#).



Figure 19 B200 M3/M4 to 2208XP Fabric Extenders

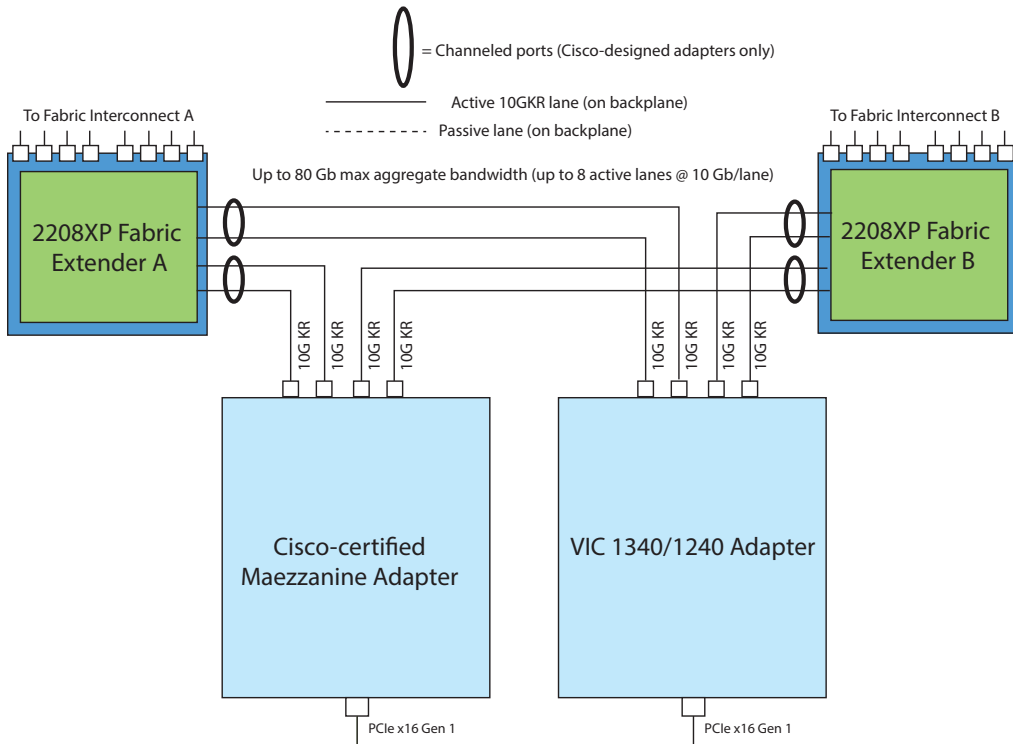

Figure 20 B200 M3/M4 to 2204XP Fabric Extenders

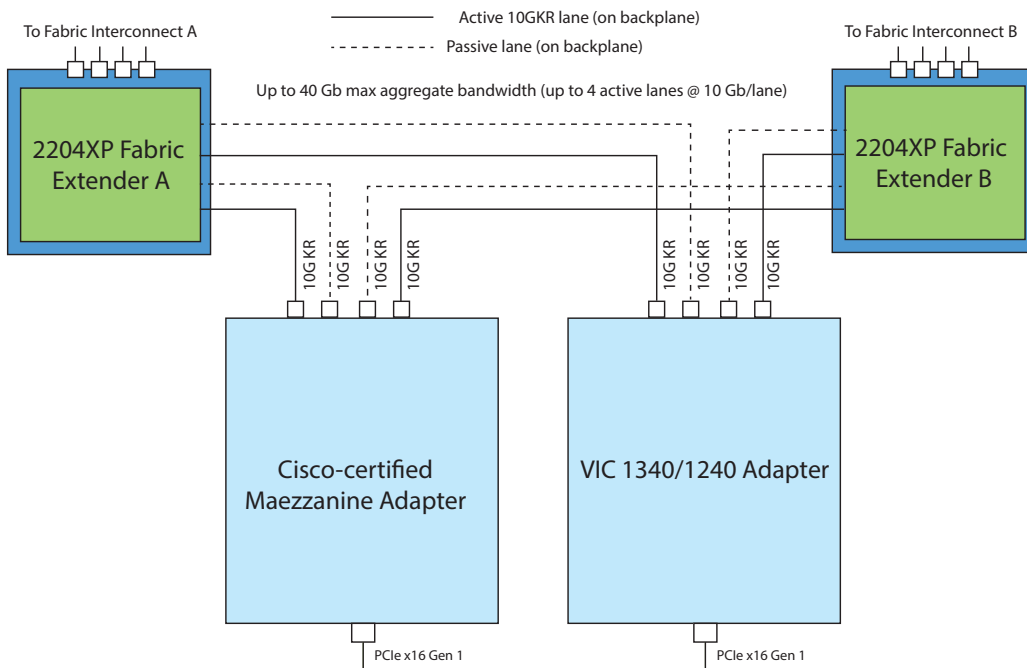
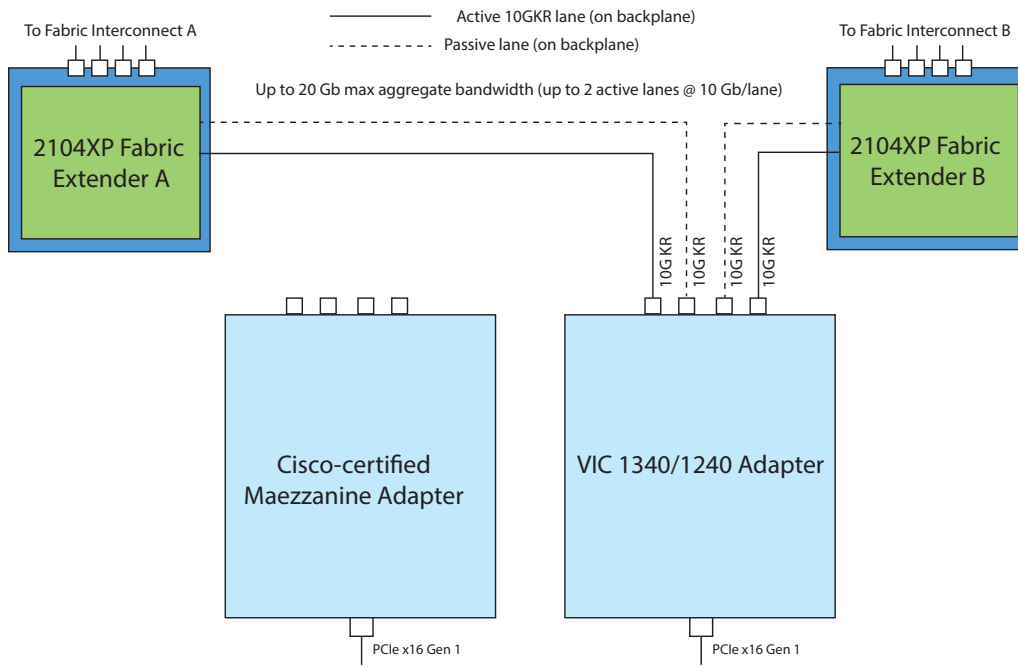

Figure 21 B200 M3/M4 to 2104XP Fabric Extenders



## B420 M3/M4 Connectivity (Full-Width Blade with Three Mezzanine Slots)

Figure 22 shows in general how the B420 M3/M4 blade server connects to the fabric extenders in the UCS 5108 chassis. Several cards available for use in the three adapter card slots (see Table 23 on page 44 and Table 24 on page 45).



NOTE: The VIC 1340 and VIC 1380 are available for only the B420 M4, not the B420 M3.

Figure 22 B420 M3/M4 to Fabric Extenders

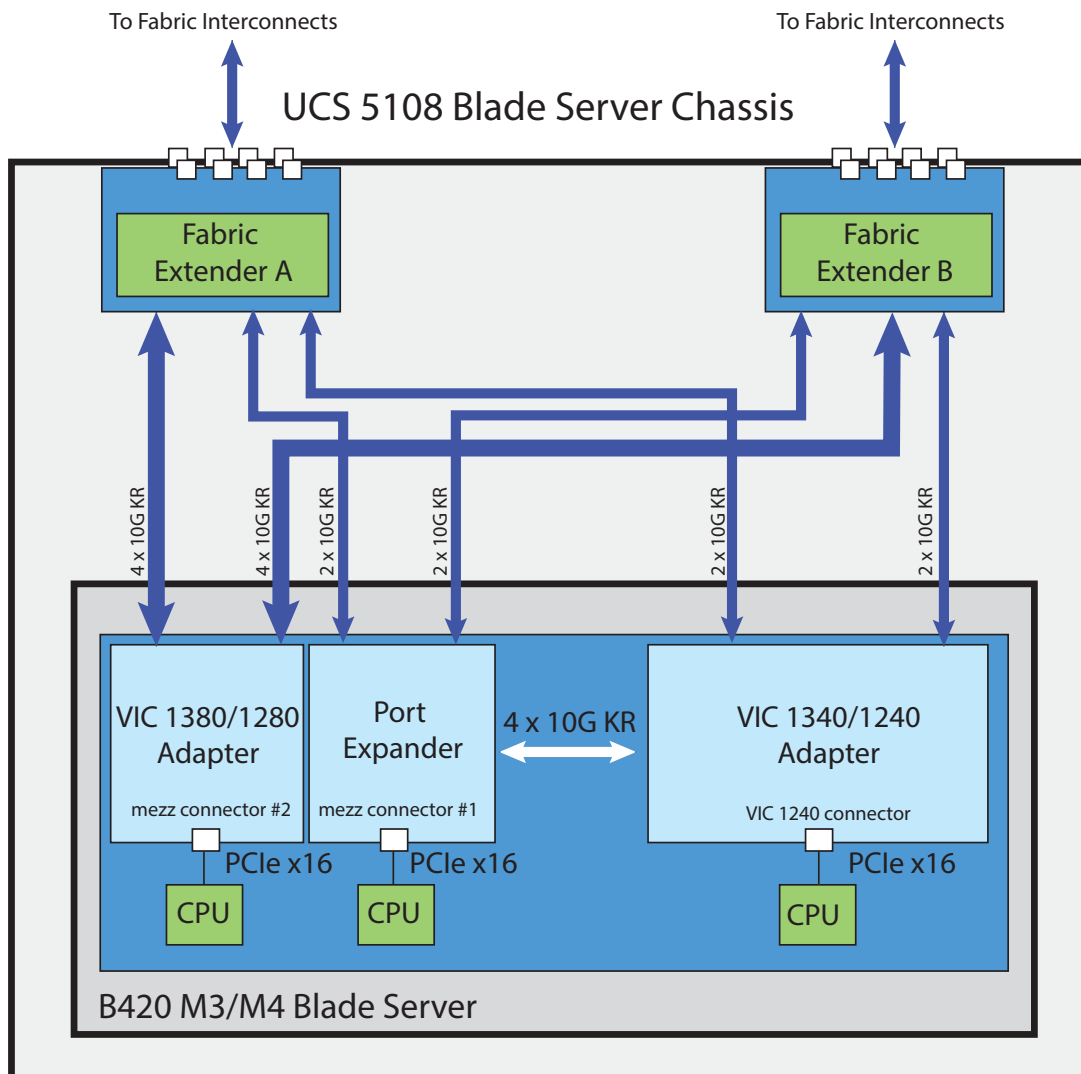

Supported 4-CPU card adapter combinations are shown in [Table 23](#).

Table 23 Supported Mezzanine Adapter Combinations (4-CPU Configuration)<sup>1</sup>

Adapter in VIC 1340/1240 Connector	Adapter in Mezzanine Slot 1	Adapter in Mezzanine Slot 2	Total Available Bandwidth <sup>2</sup>		
			2 x 2208 XP	2 x 2204 XP	2 x 2104 XP
VIC 1340/1240	Not populated	Not populated	40 Gb	20 Gb	20 Gb
VIC 1340/1240	Not populated	VIC 1380/1280	120 Gb	60 Gb	40 Gb
Not populated	Not populated	VIC 1380/1280	80 Gb	40 Gb	20 Gb
VIC 1340/1240	Not populated	Cisco-certified mezzanine adapter <sup>3</sup>	60 Gb	40 Gb	40 Gb
VIC 1340/1240	Port Expander Card for VIC 1340/1240	Not populated	80 Gb	40 Gb	Not supported <sup>4</sup>
Not populated	Not populated	Cisco-certified mezzanine adapter	20 Gb	20 Gb	20 Gb
Not populated	Cisco-certified mezzanine adapter	Cisco-certified mezzanine adapter	40 Gb	40 Gb	Not supported <sup>3</sup>
VIC 1340/1240	Port Expander Card for VIC 11340/1240	VIC 1380/1280	160 Gb	80 Gb	Not supported <sup>3</sup>

Notes . . .

1. The VIC 1340 and VIC 1380 are available only for the B420 M4, not the B420 M3.
2. Cisco-designed adapters are capable of port channeling. A port channel bundles up to four individual interfaces into a group to provide increased bandwidth and redundancy. Port channeling also load balances traffic across these physical interfaces. The port channel stays operational as long as at least one physical interface within the port channel is operational. Cisco-certified adapters supplied by third-party vendors do not support port channeling. Port channeling is indicated with an oval drawn around several individual ports.
3. Cisco-certified mezzanine adapters are manufactured by third-party vendors and are certified by Cisco for use in the servers. For more information about supported Cisco-certified mezzanine adapters, see [http://www.cisco.com/en/US/docs/unified\\_computing/ucs/hw/chassis/install/blade.html#wp1010426](http://www.cisco.com/en/US/docs/unified_computing/ucs/hw/chassis/install/blade.html#wp1010426)
4. The 2104XP fabric extender is not compatible with any I/O card installed in mezzanine connector 1.

Supported 2-CPU card adapter combinations are shown in [Table 24](#).

Table 24 Supported Mezzanine Adapter Combinations (2-CPU Configuration)<sup>1</sup>

Adapter in VIC 1340/1240 Connector	Adapter in Mezzanine Slot 1	Adapter in Mezzanine Slot 2	Total Available Bandwidth <sup>2</sup>		
			2 x 2208XP	2 x 2204 XP	2 x 2104 XP
VIC 1340/1240	Not populated	Not populated	40 Gb	20 Gb	20 Gb
VIC 1340/1240	Not populated	VIC 1380/1280	120 Gb	60 Gb	40 Gb
VIC 1340/1240	Not populated	Cisco-certified mezzanine adapter <sup>3</sup>	60 Gb	40 Gb	40 Gb
VIC 1340/1240	Port Expander Card for VIC 1340/1240 <sup>4</sup>	Not populated	80 Gb	40 Gb	Not supported <sup>5</sup>
Not populated	Not populated	Cisco-certified mezzanine adapter	20 Gb	20 Gb	20 Gb
VIC 1340/1240	Port Expander Card for VIC 1340/1240 <sup>3</sup>	VIC 1380/1280	160 Gb	80 Gb	Not supported <sup>4</sup>

Notes . . .

1. The VIC 1340 and VIC 1380 are available only for the B420 M4, not the B420 M3.
2. Cisco-designed adapters are capable of port channeling. A port channel bundles up to four individual interfaces into a group to provide increased bandwidth and redundancy. Port channeling also load balances traffic across these physical interfaces. The port channel stays operational as long as at least one physical interface within the port channel is operational. Cisco-certified adapters supplied by third-party vendors do not support port channeling. Port channeling is indicated with an oval drawn around several individual ports.
3. Cisco-certified mezzanine adapters are manufactured by third-party vendors and are certified by Cisco for use in the servers. For more information about supported Cisco-certified mezzanine adapters, see [http://www.cisco.com/en/US/docs/unified\\_computing/ucs/hw/chassis/install/blade.html#wp1010426](http://www.cisco.com/en/US/docs/unified_computing/ucs/hw/chassis/install/blade.html#wp1010426)
4. Only the Port Expander for VIC 1340/1240 is functional in mezzanine slot 1 in 2-CPU configurations
5. The 2104XP fabric extender is not compatible with any adapter installed in mezzanine slot 1

The general connectivity diagrams between the card adapters and the different fabric extenders are shown in [Figure 23 on page 46](#) through [Figure 26 on page 48](#).

Figure 23 is an example of how the B420 M3/M4 blade chassis implements a VIC 1340/1240 adapter with a Port Expander and VIC 1380/1280 adapter to connect to the fabric extenders.

Figure 23 B420 M3/M4 (with VIC 1340/1240, Port Expander, and VIC 1380/1280) to Fabric Extenders

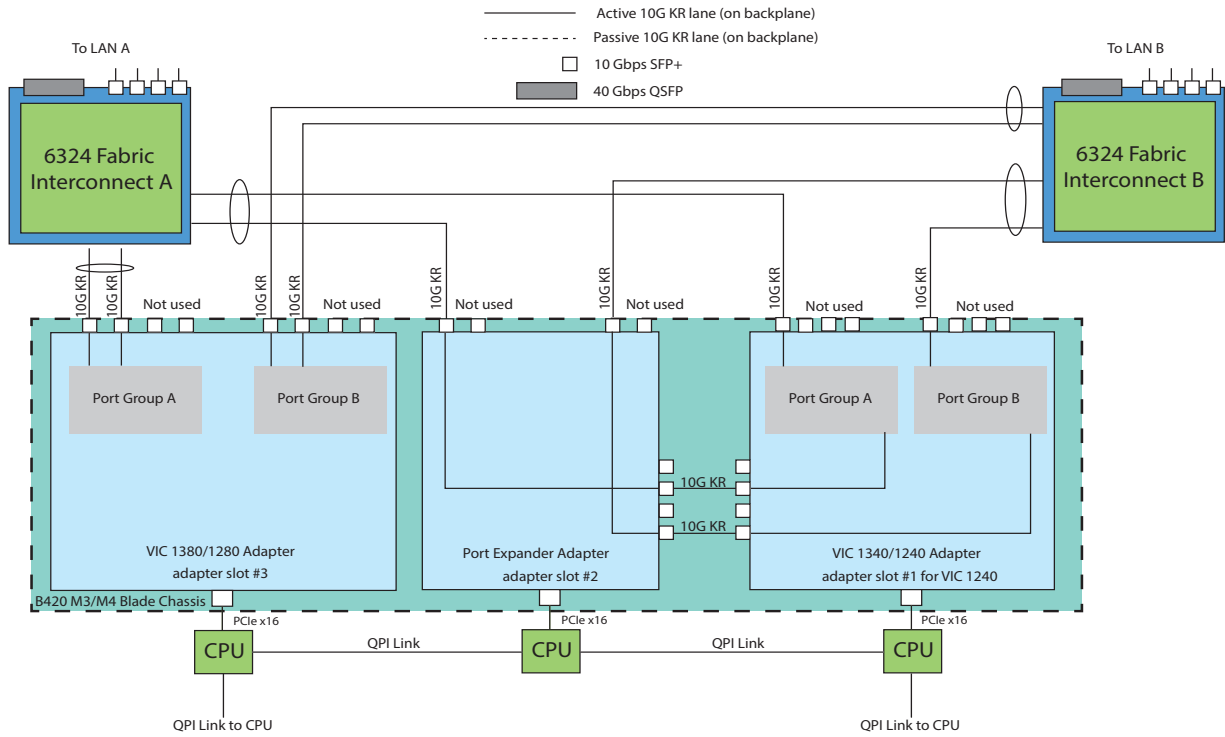

Figure 24 B420 M3/M4 to 2208XP Fabric Extenders

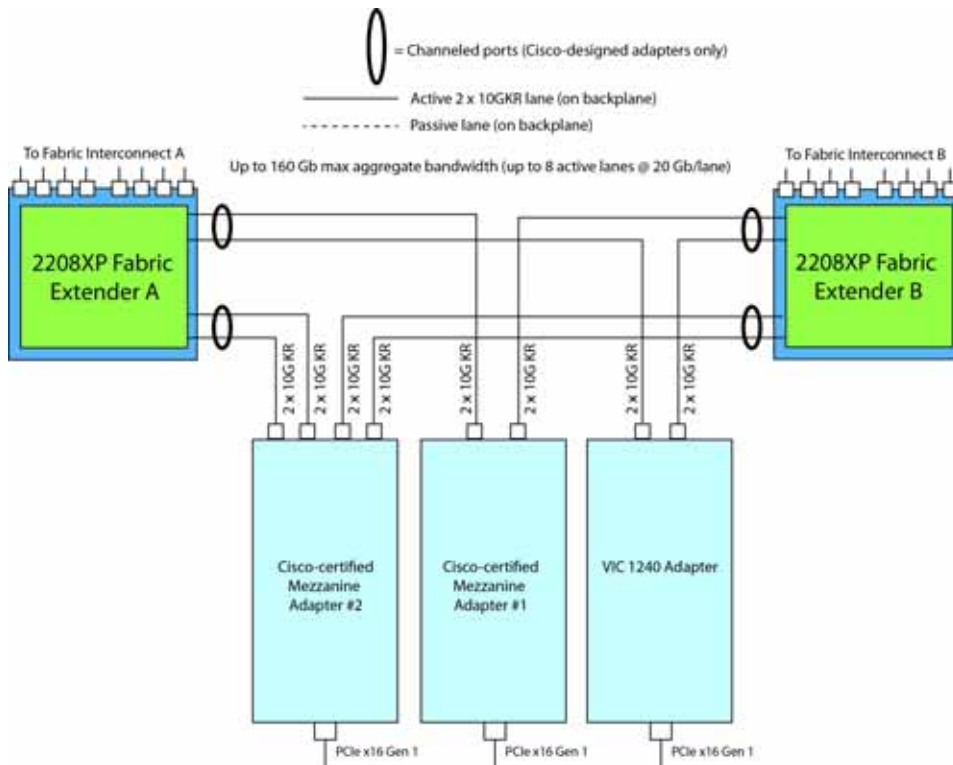

Figure 25 B420 M3/M4 to 2204XP Fabric Extenders

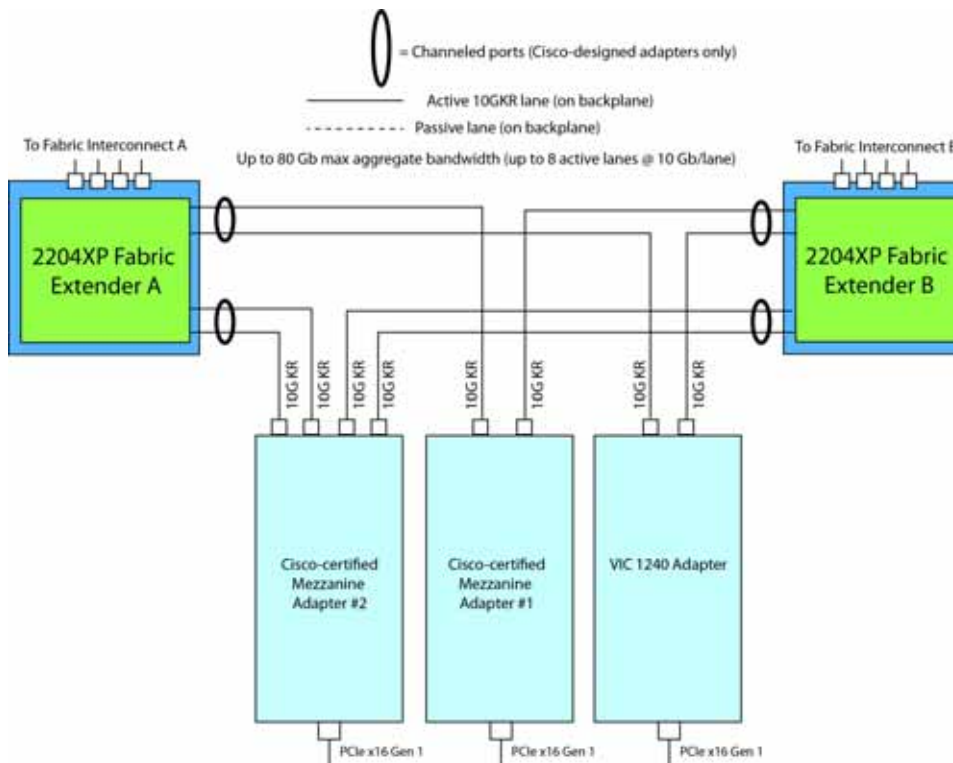
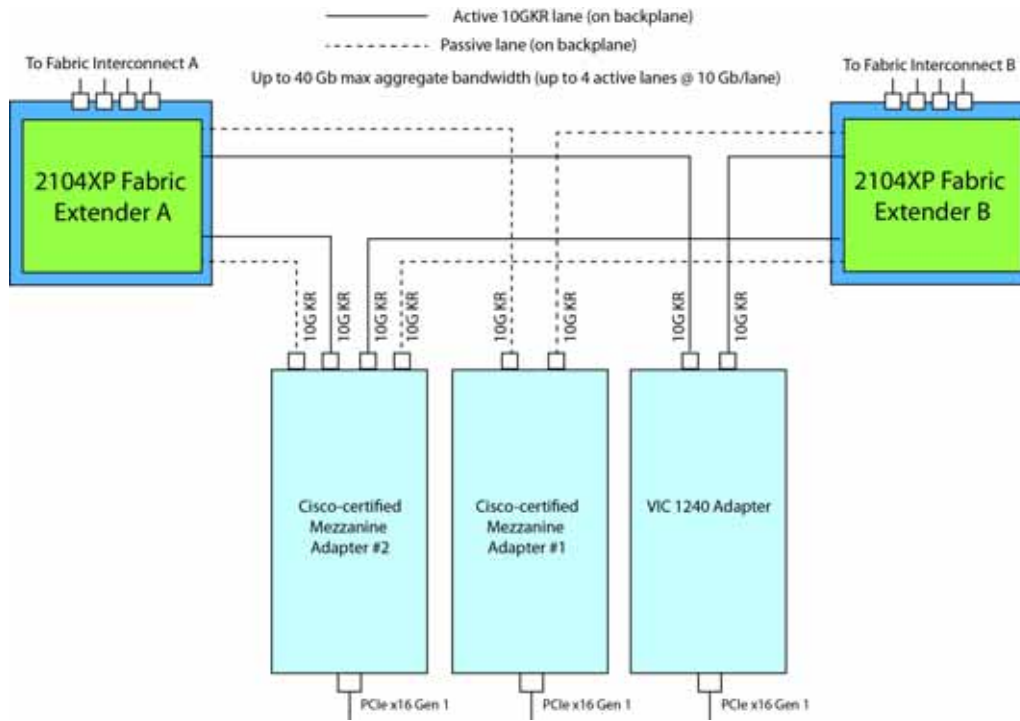

Figure 26 B420 M3/M4 to 2104XP Fabric Extenders





## Connectivity Between Fabric Extender and External Fabric Interconnects

Figure 27 shows the correct method to connect the Fabric Interconnect modules to two separate external fabric interconnects. You must connect each port fabric interconnect to the chassis through its own Fabric Extender.

Figure 27 Connecting Blade Chassis Fabric Extenders to Fabric Interconnect Chassis

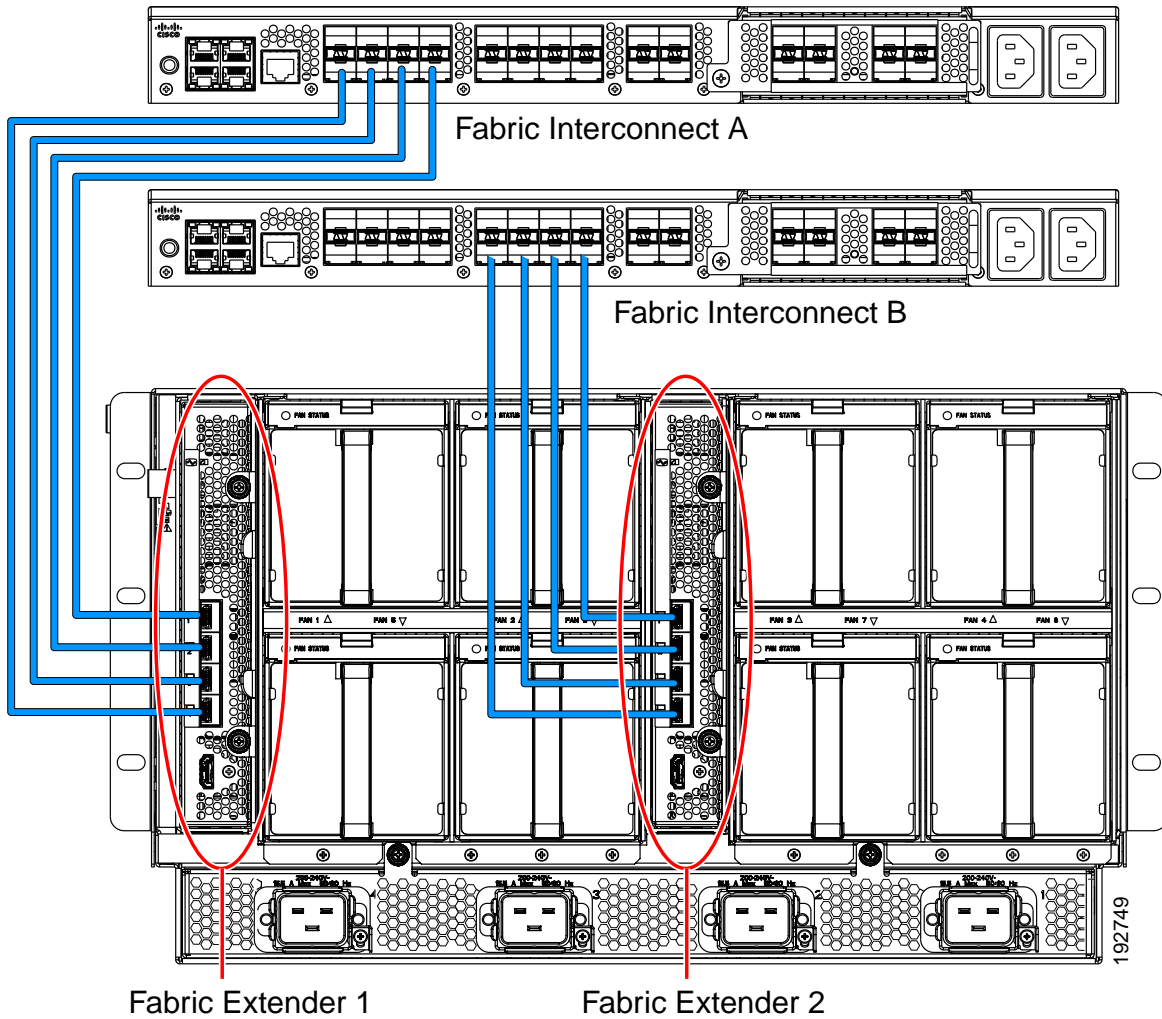

## Connectivity Between B200 M3/M4 and Internal 6324 Fabric Interconnects

Figure 28 is a system diagram showing a Cisco UCS 5108 chassis with internal Cisco UCS 6324 Fabric Interconnects connected in a system.

Figure 28 System Diagram (Cisco UCS 5108 Chassis with Internal Cisco UCS 6324 Fabric Interconnects)

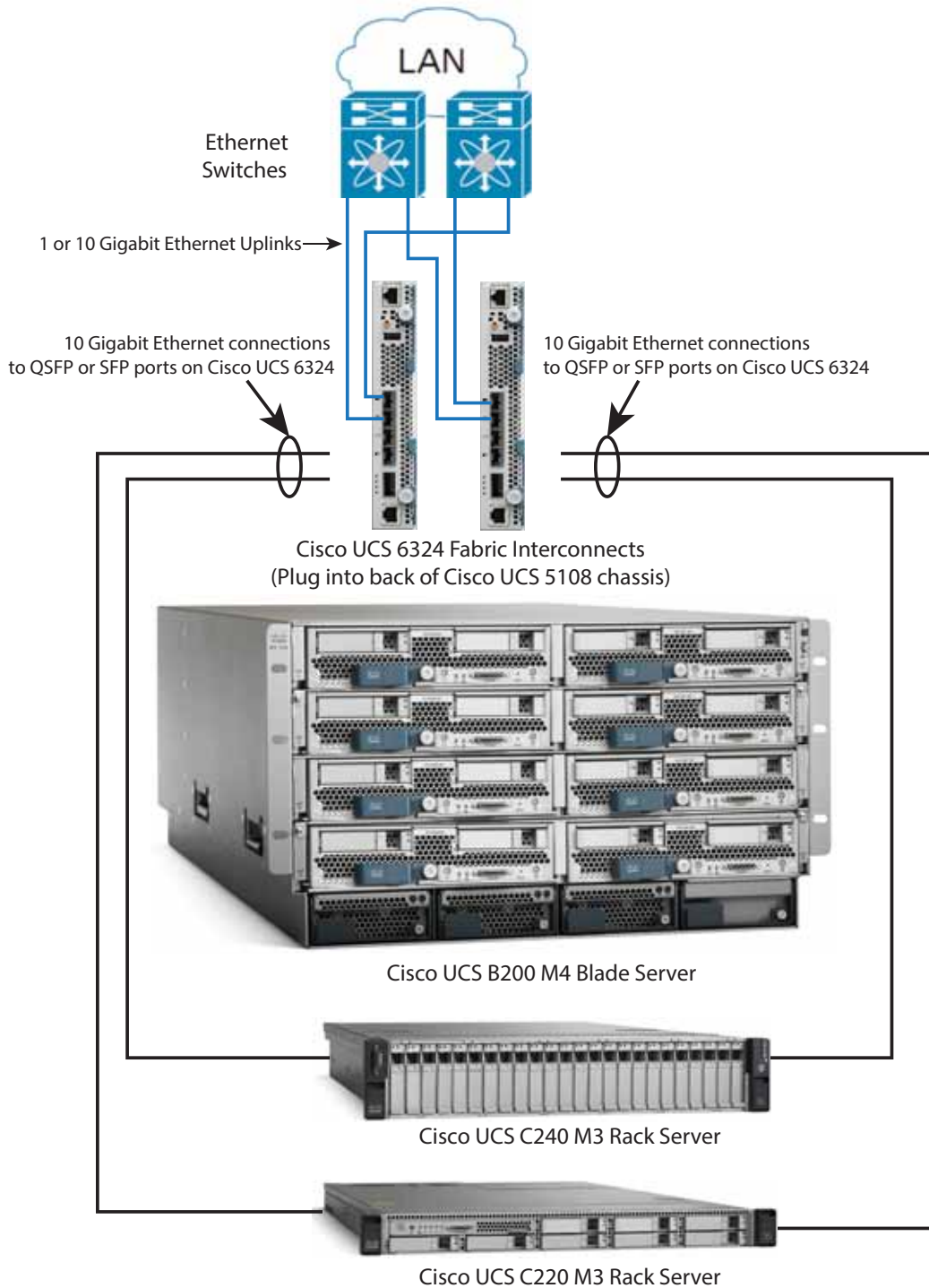

Figure 29 shows the general connectivity between a B200 M3/M4 blade and the internal 6324 FIs

Figure 29 General Connectivity Between B200 M3/M4 Blade Chassis and 6324 FIs

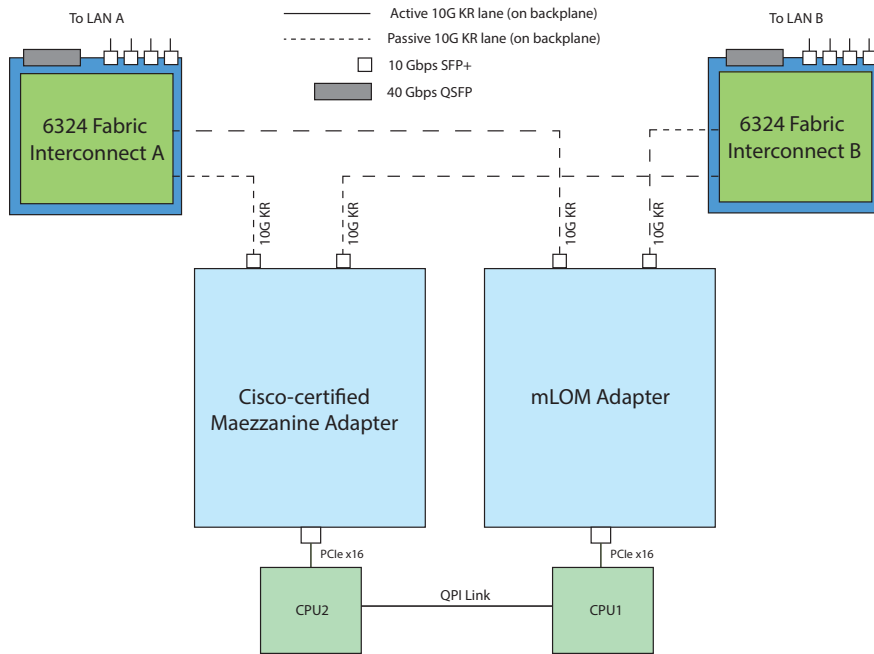

Figure 30 shows the connectivity between a B200 M3/M4 blade implementing a VIC 1340/1240 in the mLOM slot and the internal 6324 FIs.

Figure 30 Connectivity Between B200 M3/M4 Blade Chassis with VIC 1340/1240 and the 6324 FIs

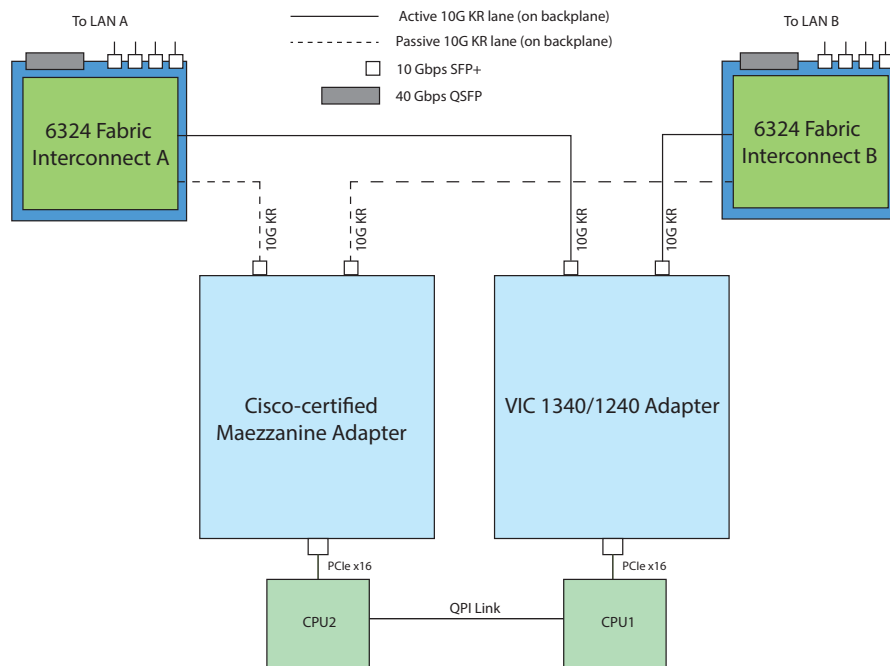

Figure 31 shows the connectivity between a B200 M3/M4 blade implementing a VIC 1340/1240 in the mLOM slot, a port expander for the VIC 1340/1240, and the internal 6324 FIs.

Figure 31 Connectivity Between B200 M3/M4 Blade Chassis with VIC 1340/1240 and Port Expander and the 6324 FIs

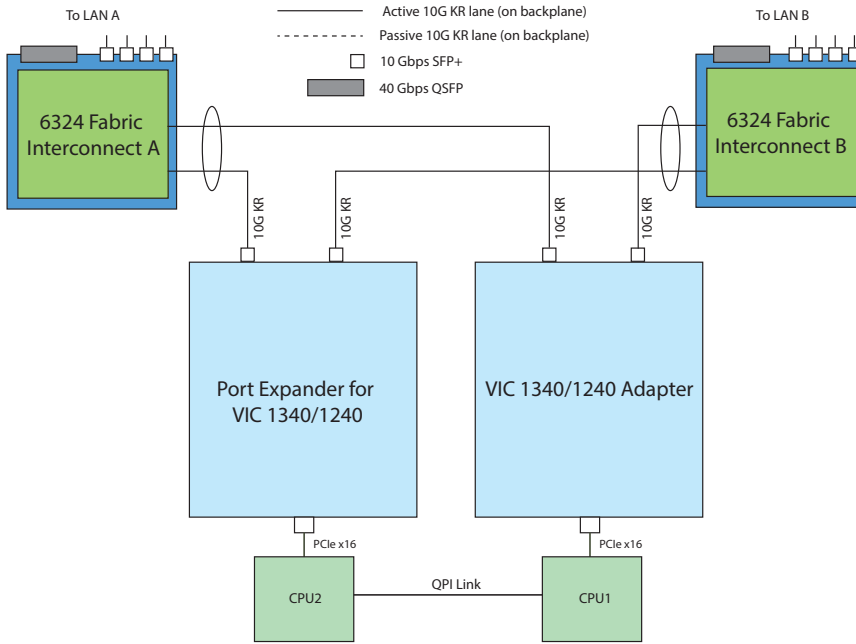
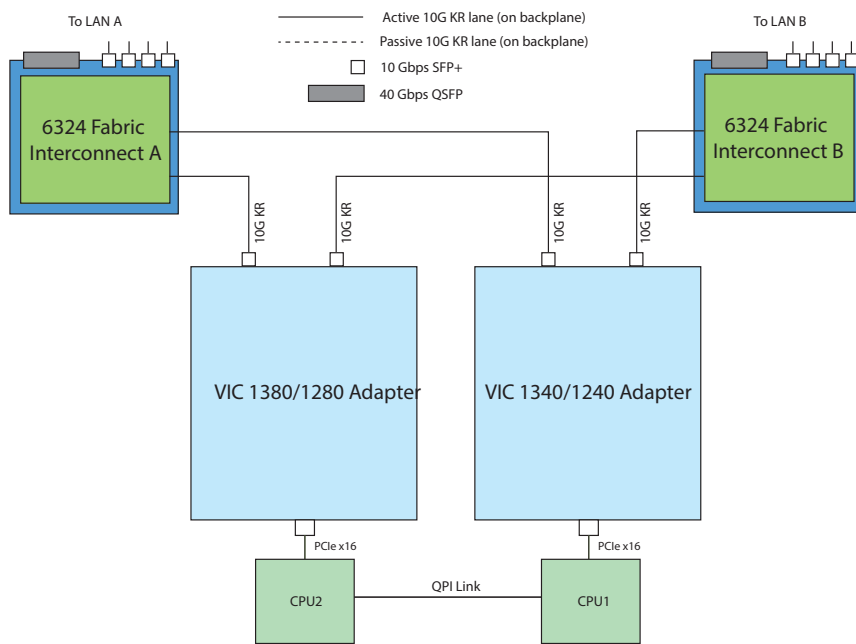

Figure 32 shows the connectivity between a B200 M3/M4 blade implementing a VIC 1340/1240 and VIC 1380/1280 and the internal 6324 FIs.

Figure 32 Connectivity Between B200 M3/M4 Blade Chassis with VIC 1340/1240 and VIC 1380/1280 and the 6324 FIs



## SFP+ Transceivers

Each Cisco Fabric Extender within the chassis supports Small Form-Factor Pluggable (SFP+) copper or optical transceivers. Each transceiver runs at 10 Gbs.

### Copper SFP+ Twinax Transceivers

The Cisco Fabric Extenders support Twinax copper transceivers with twinax cables of various lengths. The assembly consists of two transceivers connected by a twinax copper cable. The enhanced SFP+ 10-Gb Ethernet transceiver is a bidirectional device with a transmitter and receiver in the same physical package. It has a 20-pin connector on the electrical interface.

*Figure 33* shows the SFP-H10GB-CU5M transceiver. The rubber loop is used for removing the SFP+ from its port on the I/O module.

Figure 33 SFP+ 10 Gb Twinax Copper Transceiver

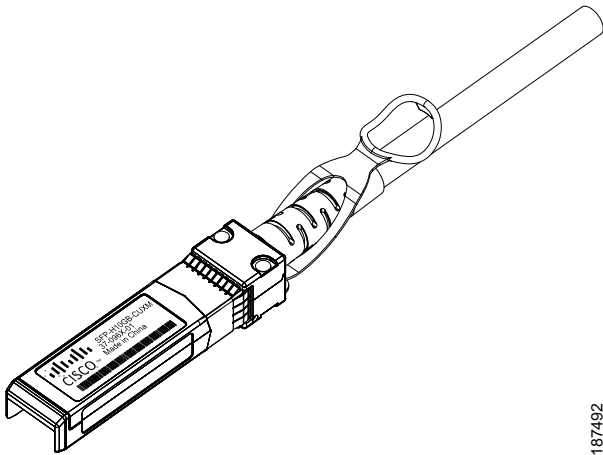

187492

## Optical SFP+ Transceivers

If distances greater than 5 meters (16.4 feet) must be spanned, the Fabric Extender supports the substitution of the copper SFP+ by optical SFP+ transceivers. The SFP+ 10-Gb Ethernet optical transceiver is a bidirectional device with a transmitter and receiver in the same physical package, as shown in [Figure 34](#). It has a duplex LC connector on the optical interface. A fiber optic cable must be used to connect the two transceivers together.

Figure 34 SFP+ Optical Transceiver

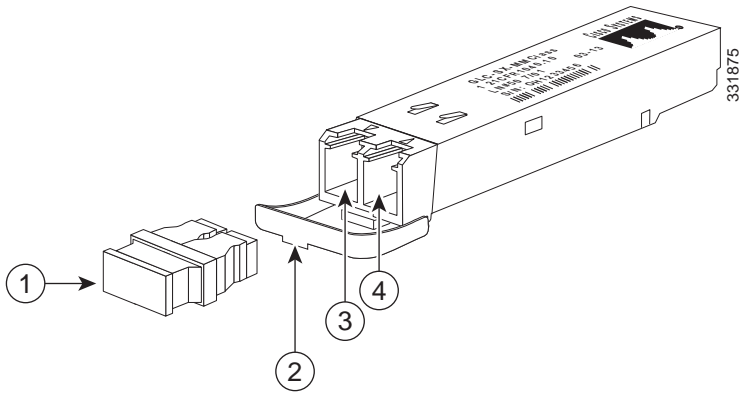

Table 25 SFP+ Callouts

Callout	Description
1	Dust plug
2	Bail clasp with clasp tab
3	Transmit bore
4	Receive bore

## Fabric Extender Bundles

You can order two kinds of Fabric Extender bundles:

- UCS-IOM2208-16FET. This bundle includes one 2208XP Fabric Extender plus 16 Fabric Extender Transceivers (FETs). 8 FETs are used for the Fabric Extender and 8 for the Fabric Interconnect.
- UCS-IOM2204-8FET. This bundle includes one 2204XP Fabric Extender plus 8 Fabric Extender Transceivers (FETs). 4 FETs are used for the Fabric Extender and 4 for the Fabric Interconnect.



**NOTE:** Cables connecting the Fabric Extender to the Fabric Interconnect using your own multimode fiber (MMF) optical cables must have the same SFP (FET-10G=) on both ends. Both the Fabric Extender ports and the corresponding Fabric Interconnect ports should implement the same SFP; otherwise, the server in the 5108 chassis might not be discovered.

---

The FETs are in an SFP+ form-factor and support 10 Gbps full-duplex transmissions between the Fabric Extender and Fabric Interconnect, using your own multimode fiber (MMF) optical cables. The reach is 25 meters using OM2 MMF optical cables and 100 meters using OM3 MMF optical cables.

If you do not order the bundle that includes the transceivers, you can order the transceivers separately as spares (PID = FET-10G=).

## TECHNICAL SPECIFICATIONS

### Physical Dimensions and Specifications

Table 26 Cisco UCS 5108 Chassis Specifications

Parameter	Value
Height	10.5 in. (26.7 cm); 6 rack unit (6RU)
Width	17.5 in. (44.5 cm); fits standard 19-inch square-hole rack (or round hole threaded or non-threaded, with optional adapter kit)
Depth	32 in. (81.2 cm)
Weight	90 lbs (40.83 kg) empty, 255 lbs (115.66 kg) fully configured
Blade server slots	8 half-width slots, 4 full-width slots, or combination of half- and full-width slots.
IO slots (for FIs or FEXs)	2
Fabric Extenders	Compatible with 2208XP, 2204XP, and 2104XP Fabric Extenders
Fabric Interconnects	Compatible with 6324 Fabric Interconnects
Power	Four Power Supplies supporting N, N+1 and N+N Grid redundancy.
Fans	8 hot-swappable fans Each fan module contains 2 redundant fans; up to two fans can fail in the system.
Management	Managed from the Cisco UCS 6100/6200 Series or 6324 fabric interconnects by Cisco UCS Manager (redundant management operations when the chassis is configured with two fabric extenders or two 6324 fabric interconnects)
Backplane	1.2 TB of aggregate throughput; supports 10BASE-KR connections for 8 blades
Regulatory compliance	Products comply with CE Markings per directives 2004/108/EC and 2006/108/EC
Safety	<ul style="list-style-type: none"> <li>■ UL 60950-1</li> <li>■ CAN/CSA-C22.2 No. 60950-1</li> <li>■ EN 60950-1</li> <li>■ IEC 60950-1</li> <li>■ AS/NZS 60950-1</li> <li>■ GB4943</li> </ul>



Table 26 Cisco UCS 5108 Chassis Specifications *(continued)*

Parameter	Value
EMC: Emissions	<ul style="list-style-type: none"><li>■ 47CFR Part 15 (CFR 47) Class A</li><li>■ AS/NZS CISPR22 Class A</li><li>■ CISPR2 2 Class A</li><li>■ EN55022 Class A</li><li>■ ICES003 Class A</li><li>■ VCCI Class A</li><li>■ EN61000-3-2</li><li>■ EN61000-3-3</li><li>■ KN22 Class A</li></ul>
EMC: Immunity	<ul style="list-style-type: none"><li>■ EN50082-1</li><li>■ EN61000-6-1</li><li>■ EN55024</li><li>■ CISPR24</li><li>■ EN300386</li><li>■ KN 61000-4 Series</li></ul>

## Power Specifications

The specifications for the various 5108 power supplies are listed in [Table 27](#) through [Table 29 on page 60](#).

Table 27 AC Input Dual Voltage Platinum Power Supply (UCSB-PSU-2500ACDV) Specifications

Description	Specification								
AC input voltage	Voltage Range 100-120 VAC, 200-240 VAC nominal (range: 90-132 VAC, 180-264 VAC)								
AC input frequency	50 to 60 Hz nominal (range: 47 to 63 Hz)								
AC Input current	< 15 Amps @ 100 VAC								
Maximum Input VA	2790 VA @ 200 VAC								
Maximum output power per power supply	2500 W at 200 to 240 VAC (up to four power supplies) 1300 W at 100 to 120 VAC (up to 4 power supplies) <sup>1</sup>								
Maximum inrush current	35 A (sub cycle duration)								
Maximum hold up time	12 ms @ 2500 W								
Power supply output voltage	12 VDC								
Power supply standby voltage	3.3 VDC								
Efficiency rating	Climate Savers Platinum								
Efficiency (80Plus Platinum Certified)	<table border="1"> <thead> <tr> <th>10% load</th> <th>20% load</th> <th>50% load</th> <th>100% load</th> </tr> </thead> <tbody> <tr> <td>93.5%</td> <td>94.9%</td> <td>95%</td> <td>93%</td> </tr> </tbody> </table>	10% load	20% load	50% load	100% load	93.5%	94.9%	95%	93%
10% load	20% load	50% load	100% load						
93.5%	94.9%	95%	93%						
Input connector	IEC320 C20								

Notes . . .

1. Only supported with Cisco UCS 6324 Fabric Interconnect

Table 28 DC Input Power Supply (UCSB-PSU-2500DC48) Specifications

Description	Specification			
Minimum software requirement	Cisco UCS Manager Release 2.0(1) Capability Catalog Version 42			
DC input voltage	-48 VDC to -60 VDC nominal (range: -40 to -72 VDC)			
Maximum output power per power supply	2500 W			
Maximum inrush current	35 A (sub cycle duration)			
Current draw at min voltage	62 A			
Current draw at max voltage	50 A			
Maximum input VA	2880			
Efficiency	10% load	20% load	50% load	100% load
	88.73%	91.68%	92.19%	90.51%
DC input terminal block	Accepts Panduit LCD4-14AF-L or equivalent barrel-type lug terminals with 90-degree angle, two-hole tongue, which accommodates 1/0 AWG size copper wire. The connector tongue width is 0.82 in, the stud hole spacing is 5/8 in, and the hole size is 1/4 in.			
Maximum hold up time	8 ms			

Table 29 HVDC Input Platinum Power Supply (UCSB-PSU-2500HVDC) Specifications

Description	Specification			
DC-input voltage	200 to 380 VDC nominal (Range: 180 to 400 VDC)			
Maximum DC-input current	15.5 Amps @ 200 VDC			
Maximum Input power	3100 W			
Maximum output power per power supply	2500 W			
Maximum inrush current	35 A (sub cycle duration)			
Maximum hold up time	12 ms @ 2500 W			
Power supply output voltage	12 VDC			
Efficiency rating	Climate Savers Platinum			
Efficiency (80Plus Platinum Certified)	10% load	20% load	50% load	100% load
	93.5%	94.9%	95%	93%
Input connector	IEC320 C20			

For configuration-specific power specifications, use the Cisco UCS Power Calculator at:

<https://mainstayadvisor.com/Go/Cisco/Cisco-UCS-Power-Calculator.aspx>

## Environmental Specifications

The environmental specifications for the 5108 blade chassis are listed in [Table 30](#).

Table 30 UCS 5108 Blade Server Environmental Specifications

Parameter	Minimum
Temperature operating	10° C to 35° C (50° F to 95° F)
Temperature nonoperating	-40° C to 65° C (-40° F to 149° F)
Altitude operating	0 to 3, 000 m (0 to 10,000 ft.); maximum ambient temperature decreases by 1° per 300 m
Humidity operating	10 to 90%, non-condensing
Humidity nonoperating	5 to 93%, non-condensing
Vibration nonoperating	2.2 Grms, 10 minutes per axis on each of the three axes
Shock operating	Half-sine 2 G, 11 ms pulse, 100 pulses in each direction, on each of the three axes
Shock nonoperating	Trapezoidal, 25 G, two drops on each of six faces $\Delta V$ : 175 inches per second each corner on bottom face drop, 90 inches per second each corner on other five faces
Safety	UL60 950-1 No. 21CFR1040, CAN/CSA-C22.2 No. 60950-1, IRAM IEC60950-1, CB IEC60950-1, EN 60950-1, IEC 60950-1, GOST IEC60950-1, SABS/CB IEC6095-1, CCC*/CB GB4943-1995, CNS14336, CB IEC60950-1, AS/NZS 60950-1, GB4943
Emissions	47CFR Part 15 (CFR 47) Class A, AS/NZS CISPR22 Class A, CISPR2 2 Class A, EN55022 Class A, ICES003 Class A, VCCI Class A, EN61000-3-2, EN61000-3-3, KN22 Class A, CNS13438 Class A
Immunity	Verified to comply with EN55024, CISPR 24, KN 61000-4 Series, KN 24
Electrostatic discharge	Tested to ESD levels up to 15 kilovolts (kV) air discharge and up to 8 kV contact discharge without physical damage
Acoustic	<ul style="list-style-type: none"> <li>■ Sound power: 68.8 dBA at ambient temperature 23° C measured using the Dome Method</li> <li>■ GOST MsanPiN 001-96</li> </ul>



---

**Americas Headquarters**  
Cisco Systems, Inc.  
San Jose, CA

**Asia Pacific Headquarters**  
Cisco Systems (USA) Pte. Ltd.  
Singapore

**Europe Headquarters**  
Cisco Systems International BV Amsterdam,  
The Netherlands

Cisco has more than 200 offices worldwide. Addresses, phone numbers, and fax numbers are listed on the Cisco Website at [www.cisco.com/go/offices](http://www.cisco.com/go/offices).

Cisco and the Cisco Logo are trademarks of Cisco Systems, Inc. and/or its affiliates in the U.S. and other countries. A listing of Cisco's trademarks can be found at [www.cisco.com/go/trademarks](http://www.cisco.com/go/trademarks). Third party trademarks mentioned are the property of their respective owners. The use of the word partner does not imply a partnership relationship between Cisco and any other company. (1005R)